

MEGATOUCH AURORA™ Quick Set-Up Guide

Getting Started

1. Plug in and turn on the game. See Figure 1.
2. Unlock and open the rear door. See Figure 1.
3. Press the **CALIB** (Calibrate) button on the OSD board (see Figure 2) and follow the instructions on the screen to calibrate the touchscreen and joystick.
4. Press the **SET UP** button on the OSD board (see Figure 2) to enter operator setup and customize the software settings.

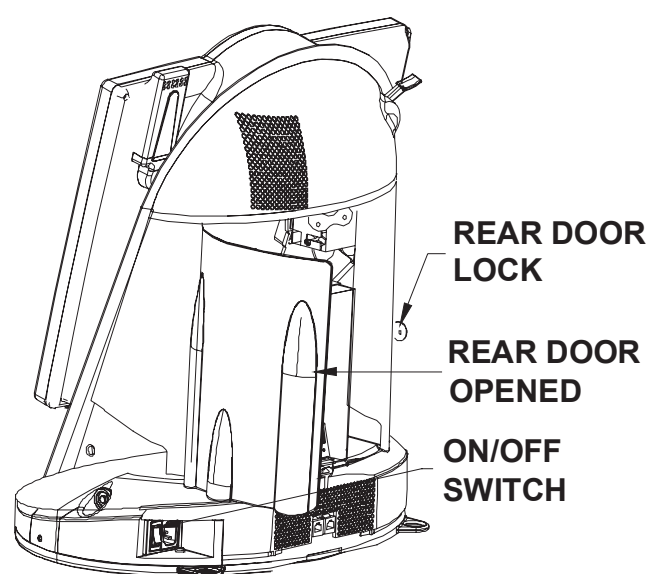

FIGURE 1 – REAR VIEW OF THE AURORA

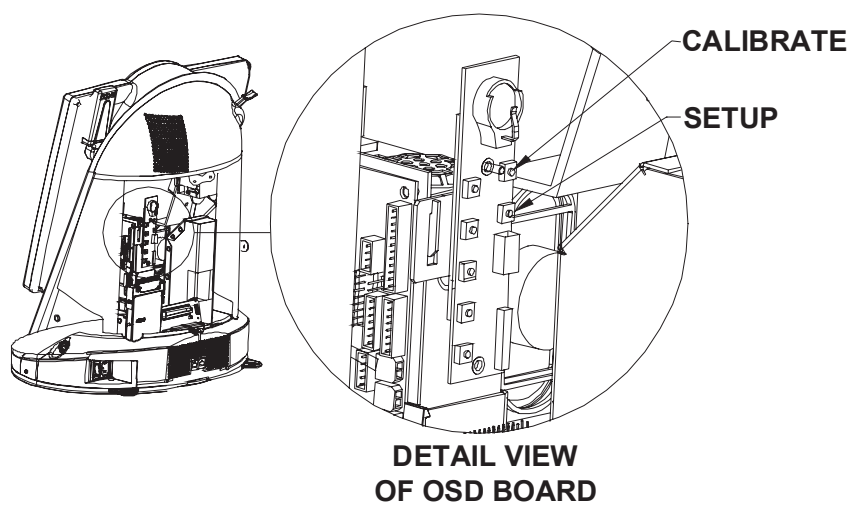

FIGURE 2 – REAR VIEW OF THE AURORA (REAR DOOR REMOVED FOR VIEWING PURPOSES)

Collecting

1. Unlock and open the rear door (see Figure 3).
2. If applicable, unlock the cash bracket lock and remove it from the game. See Figures 3 and 4.
3. Remove the coin box and/or press the blue tab on the bill acceptor to release the magazine from the game. See Figure 4.

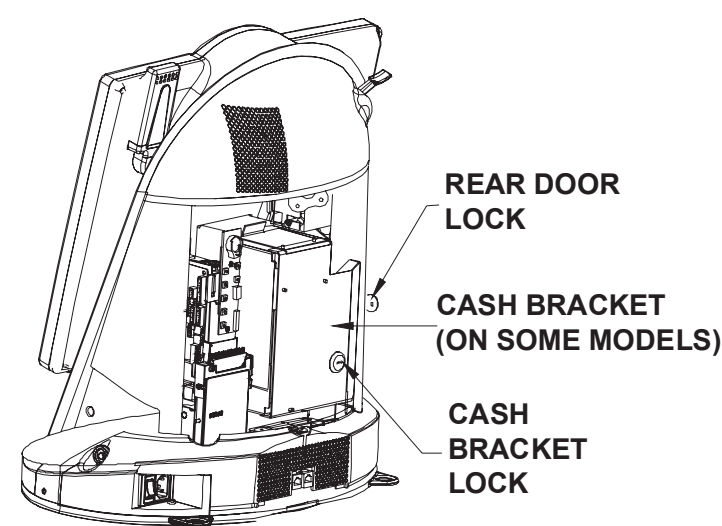

FIGURE 3 – REAR VIEW OF THE AURORA (REAR DOOR REMOVED FOR VIEWING PURPOSES)

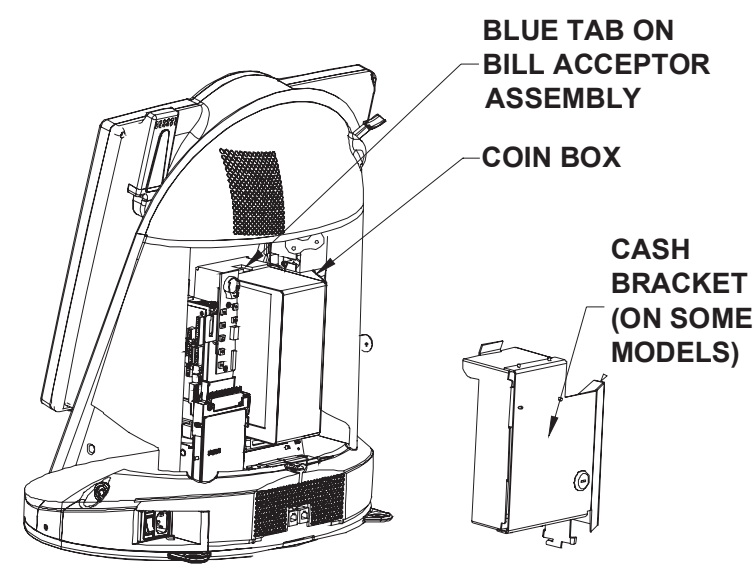

FIGURE 4 – REAR VIEW OF THE AURORA (REAR DOOR REMOVED FOR VIEWING PURPOSES)

Removing the Electronics Tray

1. Turn off and unplug the game.
2. Unlock and open the rear door (see Figure 5).
3. Reach under the center of the top of the cover to locate the rotary draw latch (see Figure 5).
4. Turn the latch left to disengage, then unscrew the thumbscrew located in the center of the bottom of the cover (see Figure 5).
5. Slowly lift the cover and disconnect the ground wire attached to the cover.
6. To remove the tray, unscrew the thumbscrew located in the middle rear of the tray (see Figure 6), and slide the tray out.

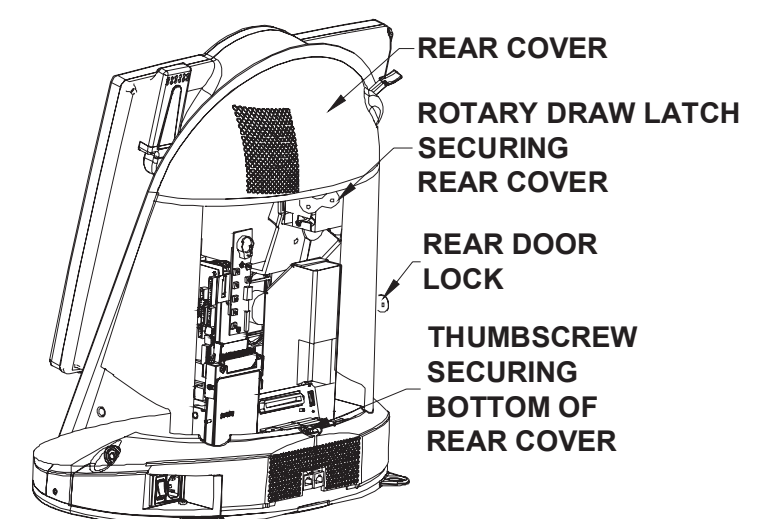

FIGURE 5 – REAR VIEW OF THE AURORA (REAR DOOR REMOVED FOR VIEWING PURPOSES)

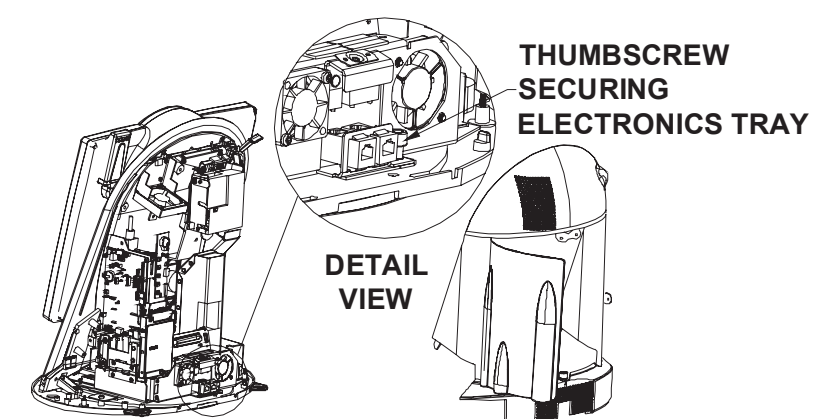

FIGURE 6 – REAR VIEW OF THE AURORA WITH THE REAR COVER REMOVED

Exploded View of the Megatouch Aurora

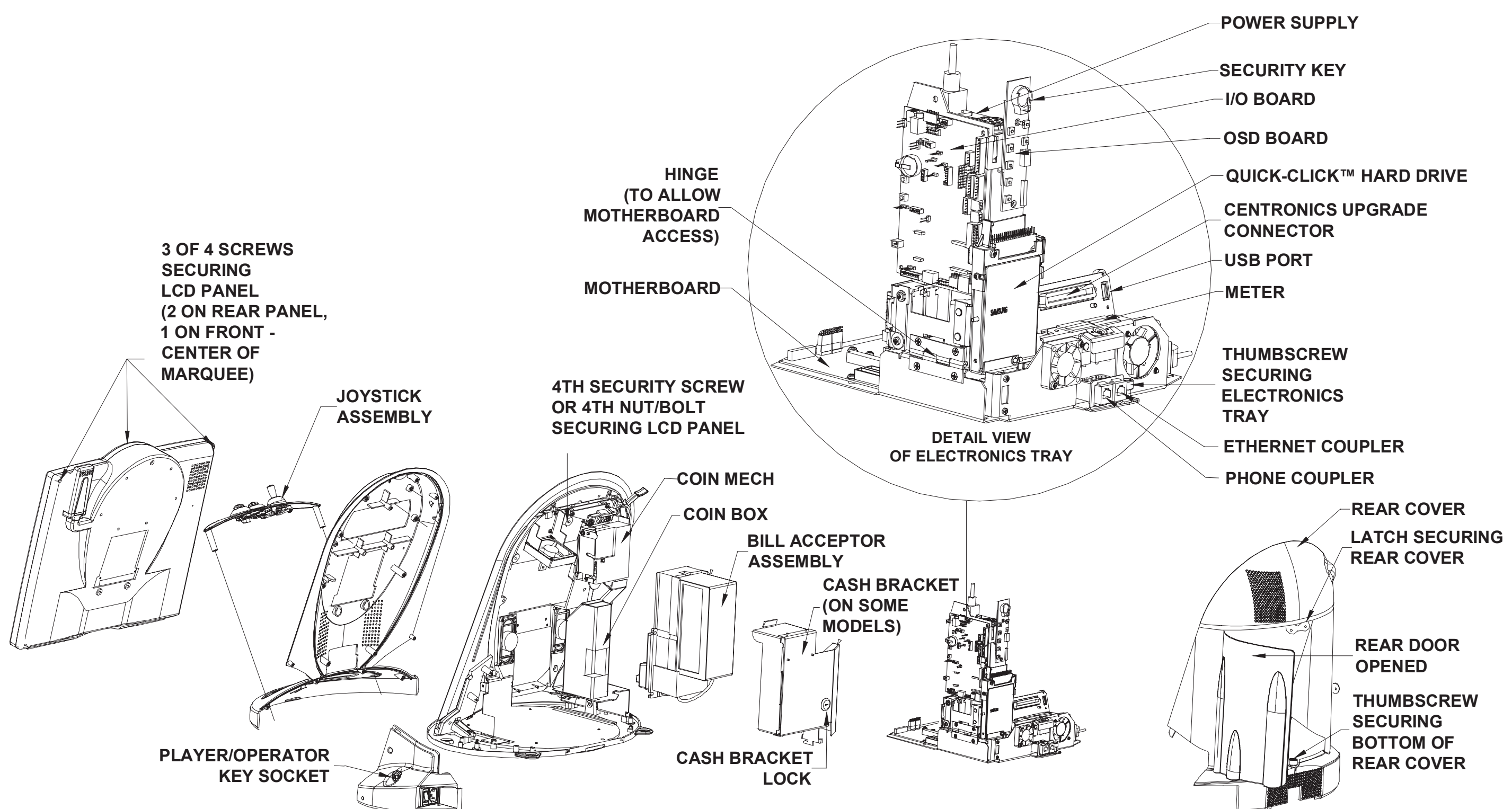

FIGURE 7 – EXPLODED VIEW OF THE AURORA

For more information see your owner's manual.
For detailed instructions on component removal and installation, see:
www.meritgames.com > Operators Arena > Support Center.