

# MEGATOUCH. **FORCE**

## **Power Supply Replacement Instructions**

Visit the Merit Entertainment Web site  
<http://www.meritgames.com>



PM0684-02



## Force Power Supply Replacement

### CONTENTS:

QTY	PART NUMBER	DESCRIPTION
1	EC7538-07	300 WATT POWER SUPPLY
1	EC0355-01	DC JUMPER CABLE
1	SB0538-01	TOUCHSCREEN & LCD POWER CABLE
2	HW7997-01	FOAM TAPE

**OVERVIEW:** Replacing the Power Supply consists of disconnecting all wires connected to the power supply, removing the old power supply, installing the new power supply, adding 2 new harnesses to this power supply, then refastening all of the connections in the unit. The following sections will walk you through both the removal of the old power supply and the installation of the new power supply:

### Power Supply Removal

1. Turn off and unplug the game.

**If your game is NOT an eVo, skip to Step 5.**

2. Unlock and open the cash tower section.
3. In the cash tower section disconnect the 4-pin connector from the LED board (see Figure 1) and carefully route the wires back through the access hole below the

motherboard (see Figure 2). It may be easier to open the CPU section while doing this, but make sure to support the CPU section as the game will become top-heavy when both sections are open.

4. Close and lock the cash tower section.
5. Unlock and open the CPU section.

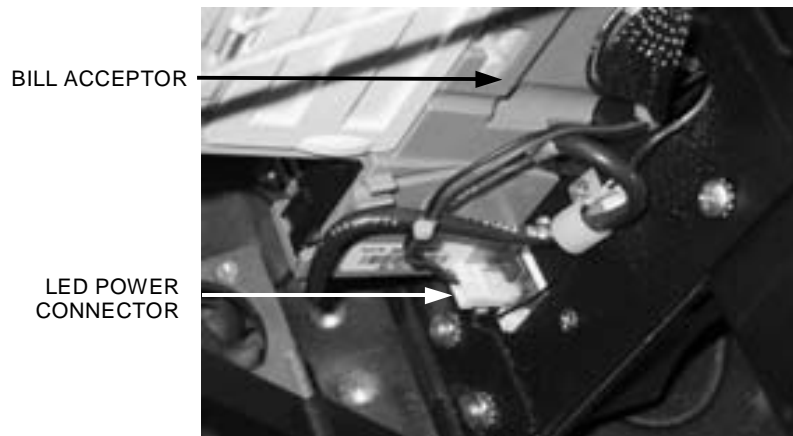

FIGURE 1 - REAR VIEW OF CPU SECTION

6. Unplug the IEC connector from the power supply (see Figure 2).
7. Disconnect the 4-pin power connector from the hard drive (see Figure 2) and follow this wire to the 2 different 2-pin connectors, which are connected to the fans. Disconnect these two connectors.
8. Disconnect the 4-pin LCD power connector (see Figure 3), then remove the wires from the cable clamp located near the hinge on the bottom right.
9. Remove the 2 screws on the right side of the motherboard (see Figure 2) and carefully pull the right side of the motherboard forward while sliding it out from under the clips on the left side of the board.
10. Disconnect the 4-pin centronics power connector (see Figure 3).

POWER CONNECTOR

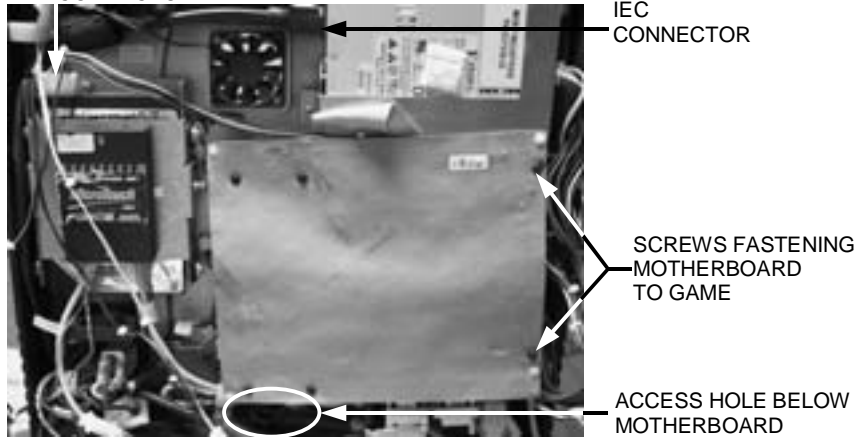

FIGURE 2 - HARD DRIVE AND MOTHERBOARD



FIGURE 3 - CLOSEUP OF CPU SECTION

11. Disconnect the 20-pin power supply connector from the motherboard (see Figure 4).
12. Disconnect the I/O board power connector from J6 on the I/O board (see Figure 4).
13. Remove the standoff securing the twist clamp in the upper right corner of the game, then undo and remove the clamp (see Figure 5).
14. Remove the 2 screws fastening the power supply mounting bracket to the game (see Figure 5) and remove the power supply.

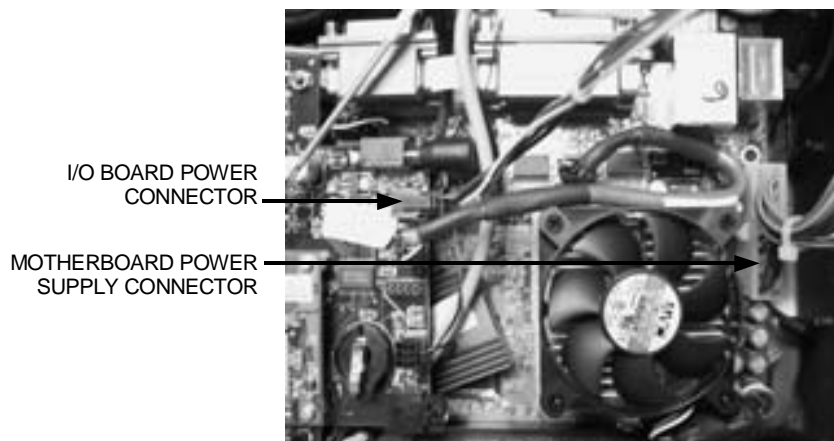

FIGURE 4 - CLOSEUP OF MOTHERBOARD

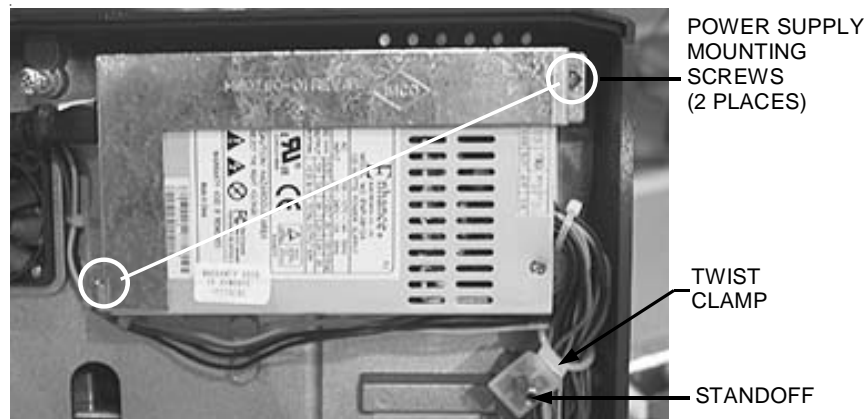

FIGURE 5 - POWER SUPPLY

### Power Supply Installation

**NOTE:** The replacement power supply may be slightly smaller in size than the power supply that was in your unit. Because of this, additional foam tape may need to be added to the power supply mounting bracket. If there is already a double layer of foam tape on the bracket, you do not need to install additional tape. If there is only a single layer of tape, and the new power supply isn't seated correctly, follow the guide in Figure 6 below to properly install the provided tape on top of the existing tape.

1. Install the new power supply by placing it in the unit and securing it with the screws and bracket that held the old power supply (see Figure 5). Be sure that the power supply is installed with the IEC connector on the top-left.
2. Replace the twist clamp around the larger set of wires that will run to the motherboard and I/O board, then reinstall the standoff (see Figure 5).
3. Attach the 20-pin connector on the provided DC jumper cable (EC0355) to the 20-pin mating connector coming from the power supply (see Figure 7).

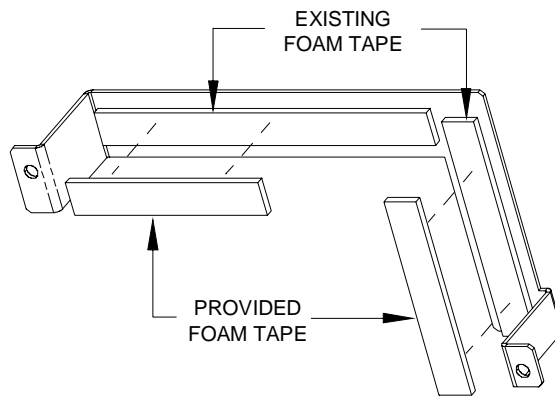

FIGURE 6 - FOAM TAPE INSTALLATION ON POWER SUPPLY MOUNTING BRACKET

Continue connecting the DC jumper cable as shown in Figure 7. For more detail, follow the steps below:

- Connect the 20-pin power supply connector to the motherboard (see Figure 4).
  - Connect the appropriate 4-pin connector to the centronics power connector (see Figure 3).
  - Connect the mating 4-pin connector to J6 on the I/O board (see Figure 4).
  - Reconnect the hard drive power connector (see Figure 2) using the appropriate 4-pin connector.
4. Replace the motherboard by sliding it under the clamps on the left side of the game, then lining up the two screw holes on the right side of the board with the two standoffs in the game. Replace the 2 screws that fasten the board to the game (see Figure 2). Make sure no wires are pinched after the motherboard is in place, and make certain that the remaining 4-pin connector coming from the new power supply is visible and accessible.

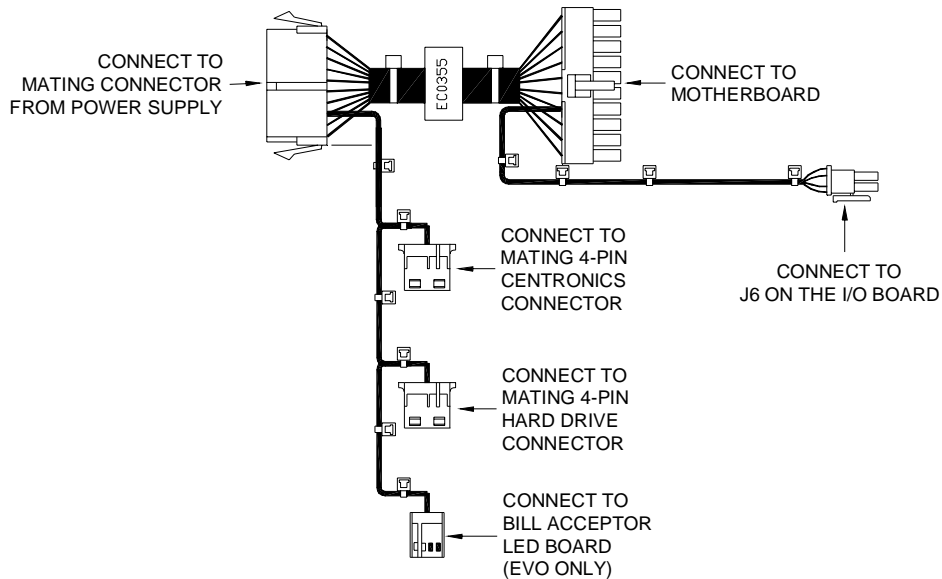

FIGURE 7 - DC JUMPER CABLE (EC0355-01) WITH CONNECTIONS

5. Connect the 4-pin mating connector on the provided touchscreen & LCD power cable (SB0538) to the remaining 4-pin connector coming from the new power supply (refer to Figure 8).

Continue connecting the touchscreen & LCD power cable as shown in Figure 8. For more detail follow the steps below:

- Connect the mating 2-pin connector to the upper fan, which is located next to the power supply.
  - Connect the mating 2-pin connector to the lower fan.
  - Connect the mating 4-pin connector to the LCD power connector (see Figure 3).
6. Reconnect the IEC connector to the power supply (see Figure 2).

7. Tie wrap any cables as necessary.
8. If your system is **NOT** an eVo, you have completed the power supply replacement. Close and lock the CPU section, making sure no wires interfere when the bezel is closed. **If your system IS an eVo, go on to Step 9.**

**eVo Only**

9. Unlock and open the cash tower section (be sure to support the CPU section while doing so), then route the LED power connector through the access hole below the motherboard (see Figure 2). Close and lock the CPU section. Make sure no wires interfere when the bezel is closed.
10. Connect the power connector to the LED board, which is located on the back of the CPU section (see Figure 1).
11. Close and lock the cash tower.

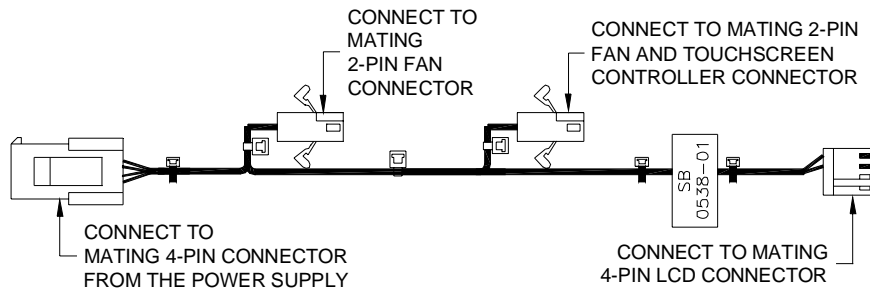

FIGURE 8 - TOUCHSCREEN & LCD POWER CABLE (SB0538-01) WITH CONNECTIONS









FORCE POWER SUPPLY REPLACEMENT INSTRUCTIONS  
PM0684-02