



merit entertainment

Aurora USB Cable Replacement

CONTENTS:

QTY	PART #	DESCRIPTION
1	EC0150-03	16" USB CABLE
3	HW8810	TIE WRAPS

1. Turn off and unplug the game.
2. Unlock the rear door and open if it is hinged (see Figure 1a), or remove if it is detachable (see Figure 1b).
3. Reach under the center of the top of the cover to locate the rotary draw latch (see Figure 1).
4. Turn the wing on the latch counterclockwise to disengage, and then unscrew the screw located in the center of the bottom of the cover (see Figure 1).

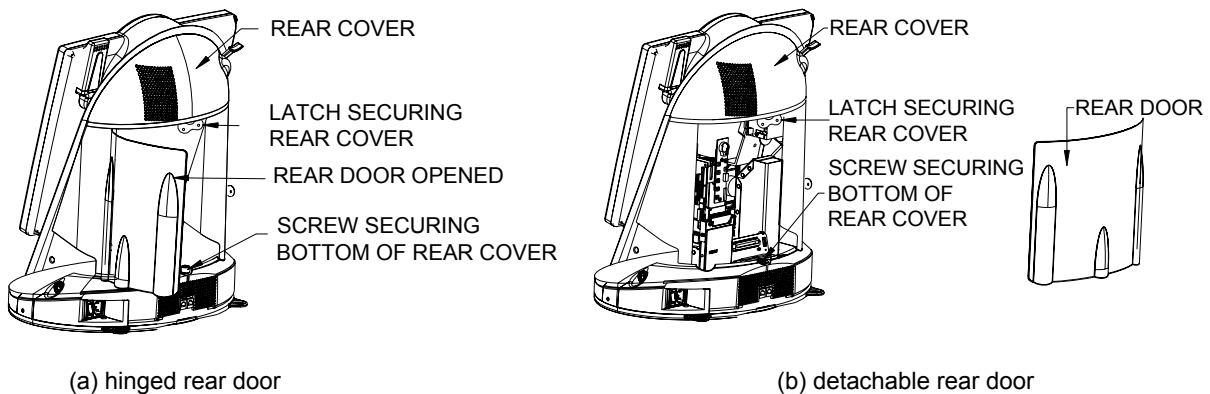

FIGURE 1 – AURORA FROM THE REAR WITH THE REAR DOOR OPENED/REMOVED

5. Slowly lift the cover and disconnect the ground wire attached to it.
6. Disconnect the power cord from the power supply. Remove the wing nut securing the OSD board and detach the board from the Velcro on the power supply bracket. See Figure 2. Carefully set the OSD board aside.

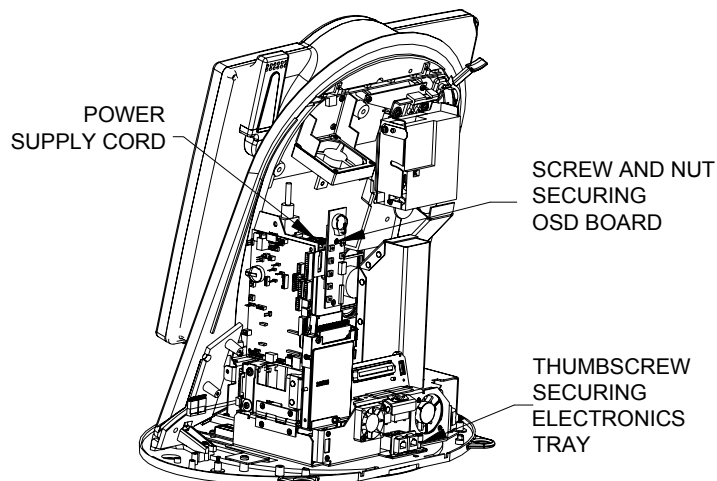

FIGURE 2 – AURORA FROM THE REAR WITH REAR COVER REMOVED



merit entertainment

7. To remove the electronics tray, unscrew the thumbscrew located in the middle rear of the tray (see Figure 2), disconnect the VGA and touchscreen connectors from the motherboard (see Figure 3), and slide the tray back.
8. Disconnect the EC0150-03 USB cable from “USB78” on the motherboard (see Figure 3) and J5 on the I/O board (see Figure 4), removing tie wraps as necessary. This USB cable will not be reused.
9. Connect the 10-pin connector on the provided EC0150-03 USB cable to “USB78” on the motherboard (see Figure 3). Connect the 4-pin connector on the USB cable to J5 on the I/O board (see Figure 4), routing the cable under the power supply and up through the gap between the I/O mounting bracket and the I/O board.

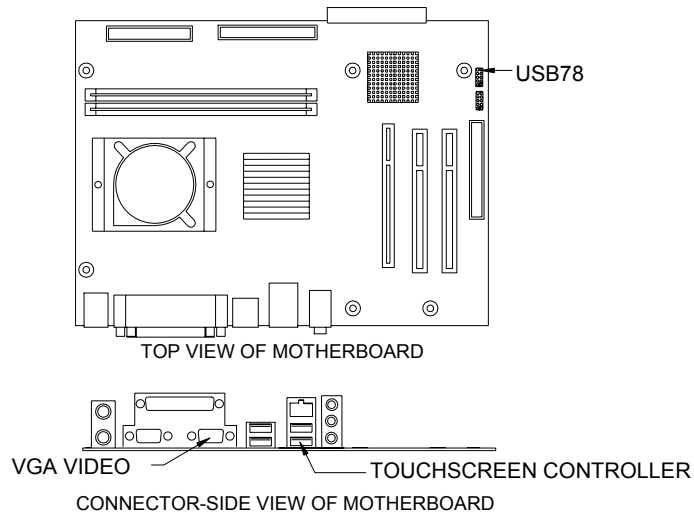

FIGURE 3 –MOTHERBOARD CONNECTIONS

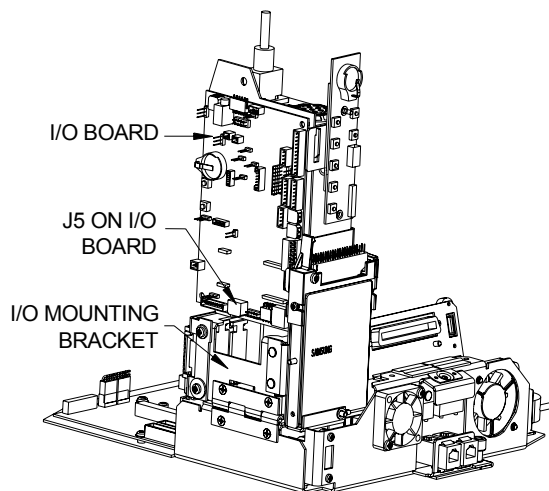

FIGURE 4 – AURORA ELECTRONICS TRAY



merit entertainment

10. Tie-wrap the EC0150-03 USB cable to its neighboring cables. Slide the electronics tray back into place. If your electronics tray has the three connectors on the back of the hard drive bracket (see Figure 5), make sure that the connectors click into the connectors on the wall of the chassis (see Figure 5).

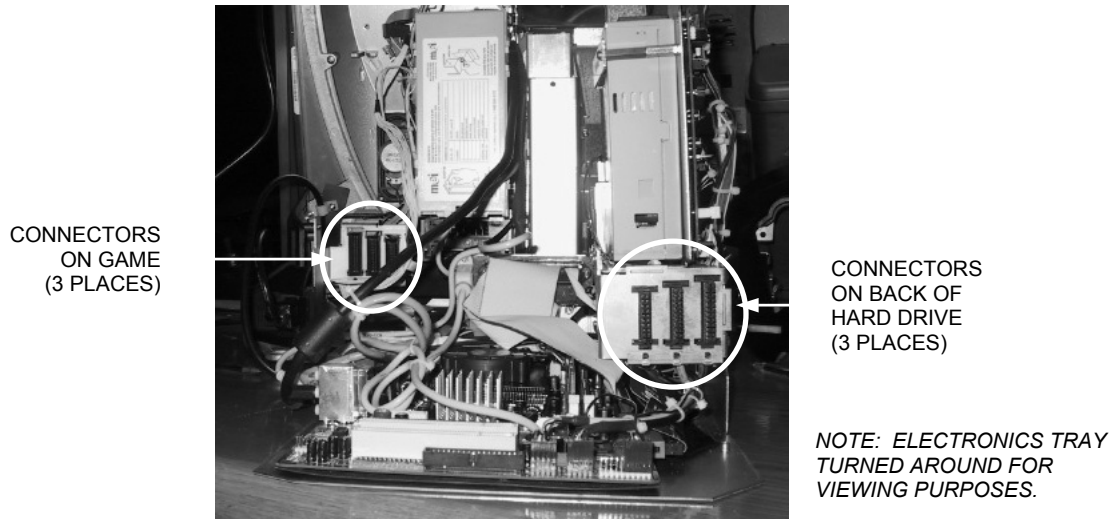

FIGURE 5 - CONNECTORS ON BACK OF HARD DRIVE BRACKET AND WALL OF GAME (SELECT GAMES ONLY)

11. Reconnect the VGA and touchscreen connectors to the motherboard. Secure the electronics tray by screwing in the thumbscrew. See Figures 3 and 2.
12. Reconnect the power cord to the power supply. Reattach the OSD board to the Velcro on the power supply bracket and secure with one wing nut. See Figure 2.
13. Reconnect the ground wire to the rear cover and lower the cover into place, carefully lining up the 2 tabs on the cover with the 2 mating holes on the sides of the game (see Figure 6). Make sure that the plastic lip on the bottom of the rear cover is behind the metal base. Tighten the screw securing the bottom of the door.

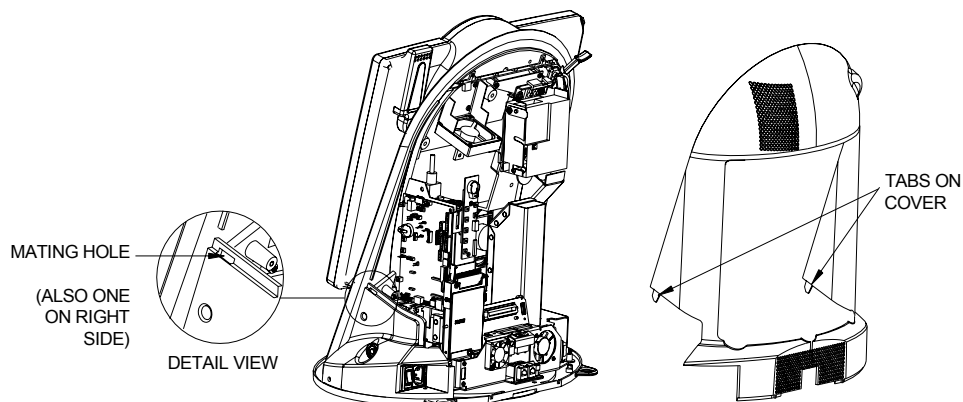

FIGURE 6 - SIDE VIEW OF GAME WITH COVER REMOVED

14. Turn the wing on the draw latch clockwise to engage the latch. See Figure 1.
15. Close (or reattach) and lock the rear door.
16. Plug in and turn on the game.