



MoD BoX Deluxe Amplifier Accessory Board Connection Instructions



Amplifier Accessory Board Connection Instructions



IMPORTANT: FOR PAGING AND MICROPHONE CAPABILITY YOU WILL NEED KIT KOV-106-000-06, -09 OR -10. (SEE PAGE 35 OF YOUR MOD BOX OWNERS MANUAL.)

Introduction:

This instruction shows you how to connect the accessory board to external audio equipment, so please read all of this introductory material.

You should save these instructions for future reference. Many different connection schemes are possible, and additional options and configurations can be added to existing connections.

If you want to use the accessory board in a configuration that is not described, or if you have difficulty installing one of the configurations, refer to the accessory board block diagram (Figure 13), schematic diagram (Figure 14), and the installation tips and techniques at the end of this installation instruction.

Preparation

Before you begin, study the configuration that you wish to use to determine which jumpers and audio cables will be needed to complete the installation (external cables for connecting from the accessory board to other equipment must be purchased or assembled).

When you have obtained all of the cables, continue with the installation.

External Connections

You are now prepared to connect the external devices. There are 4 different and independent types of connections possible. You can connect:

- up to 2 microphones
- an external preamplifier (used for tone and volume control for the entire system)
- an external music source
- a separate external amplifier

The following paragraphs, along with the accessory board block diagram (Figure 3) and schematic diagram (Figure 4), describe these connections.

PAGING MICROPHONE CONNECTIONS

The MoD BoX Paging Kit (part #KOV-106-000-06) is available through your local authorized dealer.

2 Microphones

Plug the 5-way header of the first EC1918-01 microphone cable (part of MoD BoX Paging Kit) into the microphone input header on the preamplifier. (This is a piggyback connection.)

Plug the 5-way header of the EC1918-01 microphone cable for the second microphone into P3 of the amplifier accessory board.

1 Microphone

Plug the 5-way header of the EC1918-01 microphone cable into P3 of the amplifier accessory board.

INDEX TO CONNECTION INFORMATION

Connection

External Preamplifier p. 4

Input

Stereo Background Music Input (Background Music, Tuner, TV) p. 5

Mono Background Music Input (Background Music, Tuner, TV) p. 6

Background Level and Switch-In Time Delay Adjustments p. 7

Stereo Auxiliary Music Input (Tuner, TV, Turntable, etc.) p. 8

External Amplifier *(Choose only one of these connection schemes)*

External Stereo Amplifier (Volume/Tone Controlled by Jukebox Preamp) p. 9

External Mono Amplifier (Volume/Tone Controlled by Jukebox Preamp) p. 10

External Stereo Amplifier (Volume/Tone Independent of Jukebox) p. 11

External Mono Amplifier (Volume/Tone Independent of Jukebox) p. 12

External Preamplifier

Use this configuration if you want the volume and tone of the entire jukebox sound system to be controlled by an external preamplifier. This configuration uses the AVC portion of the jukebox's preamp, but bypasses its tone and volume controls.



WARNING: Be sure that the equipment you are connecting to the Jukebox has an isolation transformer type power supply. Equipment that does not have an isolation transformer can damage the jukebox and/or create a shock hazard.

Instructions

Cables and Jumpers

Obtain four shielded audio cables long enough to reach between the external preamp and the amplifier accessory board.

This configuration requires only one of the three jumpers supplied with the accessory board. Connect this jumper between:

1. J9 (LH CH INPUT) and J14 (INVERTER OUTPUT).

Input and Output Connections

Connect the input to the external preamp as follows:

1. Preamp RIGHT CH INPUT to J4 (RIGHT CH PREAMP AUX OUTPUT)
2. Preamp LEFT CH INPUT to J2 (LEFT CH PREAMP AUX OUTPUT)

Connect the external preamp output as follows:

1. External preamp RIGHT CH OUTPUT to J12 (RIGHT CH POWERAMP INPUT)
2. External preamp LEFT CH OUTPUT to J10 (INVERTER INPUT)

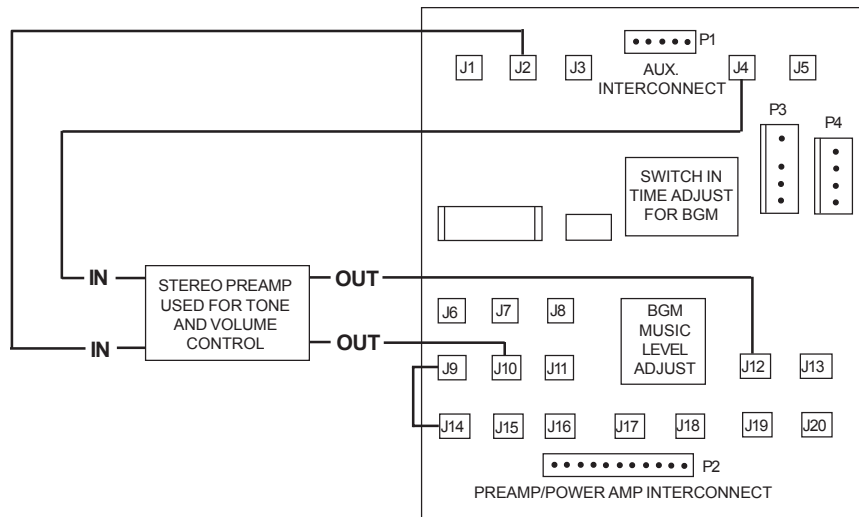



FIGURE 4 - EXTERNAL PREAMP CONNECTIONS

Stereo Background Music Input

Connect a stereo device as described here to provide background music from an external source during periods that the jukebox is not playing a paid selection. The volume of this music (generally lower than paid selections) is adjusted on the amplifier accessory board as described on Page 9. The jukebox preamplifier settings are used for tone control. A device connected to this input will not be heard during pages, or while the jukebox is playing a selection.



WARNING: Be sure that the equipment you are connecting to the Jukebox has an isolation transformer type power supply. Equipment that does not have an isolation transformer can damage the jukebox and/or create a shock hazard.

Instructions

Cables and Jumpers

Obtain two shielded audio cables long enough to reach between the input device (FM radio, TV, tape player, etc.) and the amplifier accessory board.

This configuration requires all three jumpers supplied with the accessory board. Connect these jumpers between:

1. J9 (LEFT CH POWERAMP INPUT) and J14 (INVERTER OUTPUT).
2. J13 (RIGHT CH POWERAMP INPUT) and J20 (RIGHT CH PREAMP OUTPUT).
3. J11 (INVERTER INPUT) and J16 (LH CH OUTPUT).

Input Level Considerations

The background music input can accept a wide range of input levels. You can connect speaker lines, aux. outputs or line outputs.

Input Connections

Connect the input cable from the music source as follows:

1. RIGHT CHANNEL J8 (RH CH BGM)
2. LEFT CHANNEL J6 (LH CH BGM)

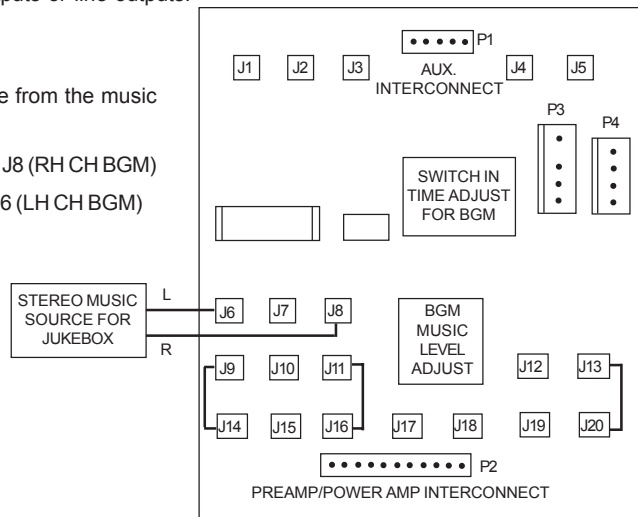



FIGURE 5 - STEREO BACKGROUND MUSIC CONNECTIONS

Mono Background Music Input

Connect a mono device as described here to provide background music from an external source during periods that the jukebox is not playing a paid selection. The volume of this music (generally lower than paid selections) is adjusted on the amplifier accessory board as described on Page 9. The jukebox preamplifier settings are used for tone control. A device connected to this input will not be heard during pages, or while the jukebox is playing a selection.



WARNING: Be sure that the equipment you are connecting to the Jukebox has an isolation transformer type power supply. Equipment that does not have an isolation transformer can damage the jukebox and/or create a shock hazard.

Instructions

Cables and Jumpers

Obtain one shielded audio cable long enough to reach between the input device (FM radio, TV, tape player, etc.) and the amplifier accessory board.

This configuration requires all three jumpers supplied with the accessory board. Connect these jumpers between:

1. J9 (LEFT CH POWER AMP INPUT) and J14 (INVERTER OUTPUT).
2. J13 (RIGHT CH POWERAMP INPUT) and J20 (RIGHT CH PREAMP OUTPUT).
3. J11 (INVERTER INPUT) and J16 (LH CH OUTPUT).

Input Level Considerations

The background music input can accept a wide range of input levels. You can connect speaker lines, aux. outputs or line outputs.

Input Connections

Connect the input cable from the music source as follows:

1. Music source output to J7 (BGM MONO)

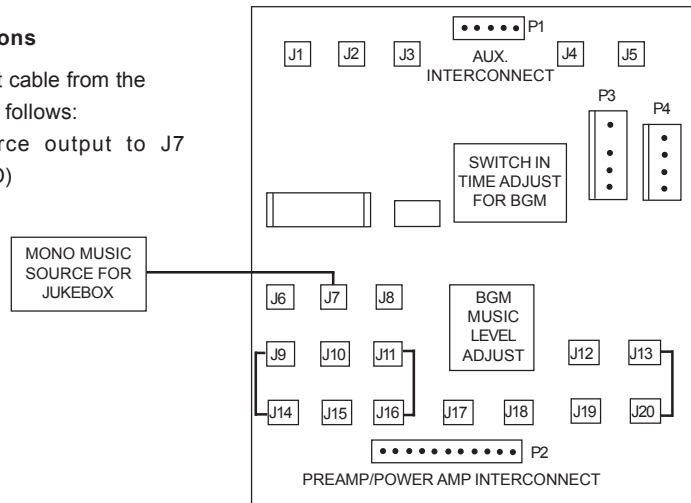

FIGURE 6 - MONO BACKGROUND MUSIC CONNECTIONS

Background Level and Switch-In Time Delay Adjustments

Background Level Adjustment

1. Select a song from the jukebox and make sure that the jukebox volume is at the desired level.
2. Cancel the song, turn the SWITCH-IN TIME adjustment clockwise as far as it will go.
3. When the background music begins to play (in approximately 10 seconds), adjust the BGM MUSIC LEVEL control for the desired background music level.

Switch-In Time Adjustment

The Switch-In Time can be adjusted from a minimum of approximately 10 seconds to a maximum of approximately two minutes. To set this time:

1. Make another selection. While the song is playing, turn the SWITCH-IN TIME ADJUST (see Figure 2) fully clockwise (it should already be in this position if you have just finished the background music adjustment). Cancel the music. Approximately 10 seconds after the selection finishes, the background music will begin playing.
2. Turn the SWITCH-IN TIME ADJUST control counter clockwise slightly, play and cancel a record, and note the switch-in time.
3. Repeat step 2 until the desired switch-in time is reached.

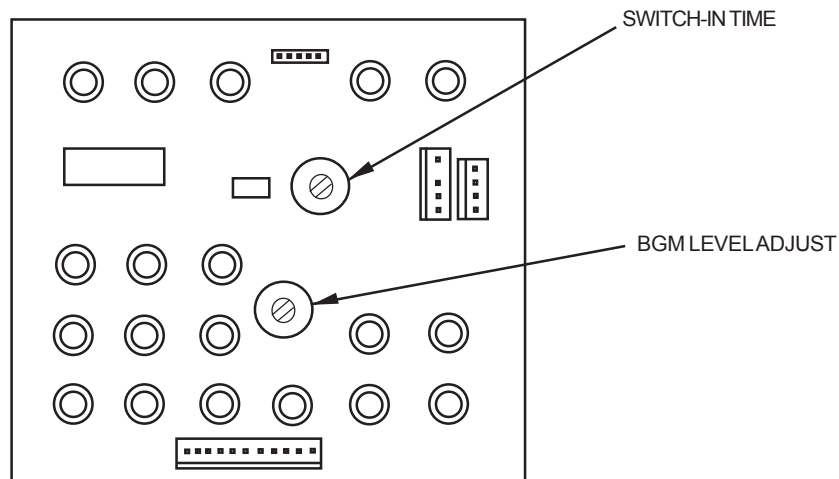



FIGURE 7 - ADJUSTMENT LOCATIONS ON AMPLIFIER ACCESSORY BOARD

Stereo Auxiliary Music Input

You can connect a stereo device as described here, but you must suspend normal jukebox operation while playing from this source. To do this, you must use the "Power" button on the optional MoD BoX Infrared Remote Control. This will suspend jukebox operation while playing the external source through the MoD BoX Amplifier and speakers (jukebox selections will remain in queue and will resume when the "Power" button is pressed again). The jukebox tone and volume controls will be used for this source as well as when the jukebox is playing normally. Quick-disconnect or switching means should be included so that the external source can be disconnected when restoring normal jukebox operation to prevent both music programs from being fed to the amplifier simultaneously.



WARNING: Be sure that the equipment you are connecting to the Jukebox has an isolation transformer type power supply. Equipment that does not have an isolation transformer can damage the jukebox and/or create a shock hazard.

Instructions

IR Remote Kit

You must obtain and install Kit # KOV-106-000-07.

Cables and Jumpers

Obtain two shielded audio cables long enough to reach between the input device (FM radio, TV, tape player, etc.) and the amplifier accessory board. Install an appropriate switch box as illustrated below.

This configuration requires all three jumpers supplied with the Accessory Board.

Connect these jumpers between:

1. J9 (LEFT CH POWERAMP INPUT) and J14 (INVERTER OUTPUT).
2. J13 (RIGHT CH POWERAMP INPUT) and J20 (RIGHT CH PREAMP OUTPUT).
3. J11 (INVERTER INPUT) and J16 (LH CH OUTPUT).

Input Connections

Connect the input cable from the music source as follows:

1. RIGHT CHANNEL J5 (RIGHT CH AUX IN)
2. LEFT CHANNEL J1 (LEFT CH AUX IN)

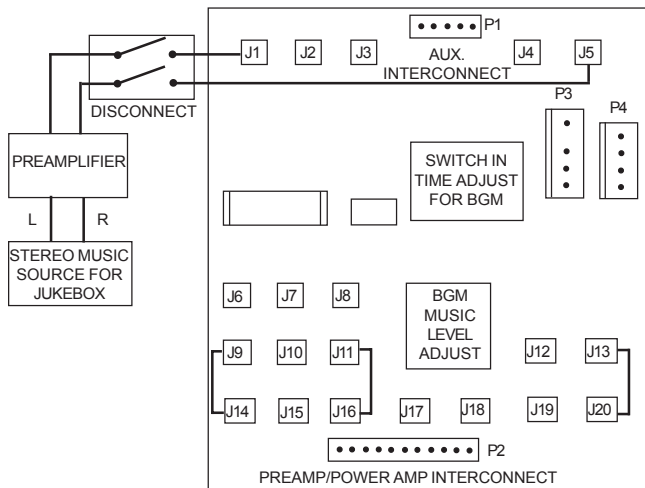



FIGURE 8 - STEREO AUXILIARY MUSIC CONNECTIONS

External Stereo Amplifier Connection - Juke Controlled

To drive extra speaker loads with an external stereo amplifier, use this configuration if you want its volume and tone to be controlled by the jukebox tone and volume controls.



WARNING: Be sure that the equipment you are connecting to the Jukebox has an isolation transformer type power supply. Equipment that does not have an isolation transformer can damage the jukebox and/or create a shock hazard.

Instructions

Cables and Jumpers

Obtain two shielded audio cables long enough to reach between the external amplifier and the amplifier accessory board.

This configuration requires all three jumpers supplied with the accessory board. Connect these jumpers between:

1. J9 (LEFT CH POWER AMP INPUT) and J14 (INVERTER OUTPUT).
2. J13 (RIGHT CH POWERAMP INPUT) and J20 (RIGHT CH PREAMP OUTPUT).
3. J11 (INVERTER INPUT) and J16 (LH CH PREAMP OUTPUT).

Input Level Considerations

The background music input can accept a wide range of input levels. You can connect speaker lines, aux. outputs or line outputs.

Input Connections

Connect the input cable from the external amplifier to the accessory board as follows:

1. Connect the external amplifier's RIGHT CH INPUT to J19 (RIGHT CH PREAMP OUTPUT).
2. Connect the external amplifier's LEFT CH INPUT to J15 (LEFT CH PREAMP OUT).

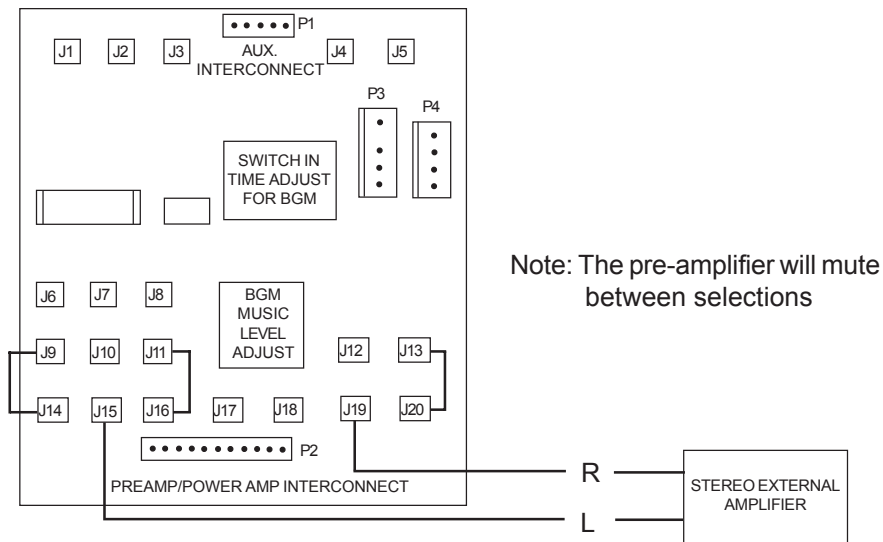



FIGURE 9 - STEREO EXTERNAL CONNECTIONS (CONTROLLED BY JUKEBOX VOLUME)

External Mono Amplifier Connection - Juke Controlled

To drive extra speaker loads with an external monaural amplifier, use this configuration if you want its volume and tone to be controlled by the jukebox tone and volume controls.



WARNING: Be sure that the equipment you are connecting to the Jukebox has an isolation transformer type power supply. Equipment that does not have an isolation transformer can damage the jukebox and/or create a shock hazard.

Instructions

Cables and Jumpers

Obtain a shielded audio cable long enough to reach between the external amplifier and the amplifier accessory board.

This configuration requires all three jumpers supplied with the Accessory Board. Connect these jumpers between:

1. J9 (LEFT CH POWERAMP INPUT) and J14 (INVERTER OUTPUT).
2. J13 (RIGHT CH POWERAMP INPUT) and J20 (RIGHT CH PREAMP OUTPUT).
3. J11 (INVERTER INPUT) and J16 (LH CH OUTPUT).

Input Connections

Connect the input cable from the external amplifier to the accessory board as follows:

1. Connect the input cable from the external amplifier INPUT to J18 (PREAMP MONO OUTPUT).

Note: The pre-amplifier will mute between selections

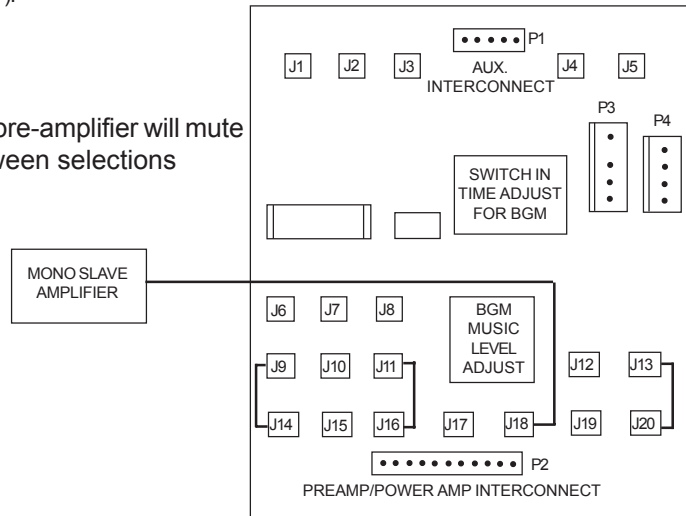
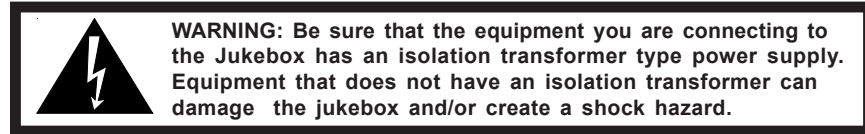

FIGURE 10 - MONO EXTERNAL AMPLIFIER CONNECTIONS
(CONTROLLED BY JUKEBOX VOLUME)

External Stereo Amplifier Connection - No Juke Control

To drive extra speaker loads with an external stereo amplifier, use this configuration if you wish to use the volume and tone controls of the external amplifier.



Instructions

Cables and Jumpers

Obtain two shielded audio cables long enough to reach between the external amplifier and the amplifier accessory board.

This configuration requires all three jumpers supplied with the accessory board. Connect these jumpers between:

1. J9 (LEFT CH POWERAMP INPUT) and J14 (INVERTER OUTPUT).
2. J13 (RIGHT CH POWERAMP INPUT) and J20 (RIGHT CH PREAMP OUTPUT).
3. J11 (INVERTER INPUT) and J16 (LH CH OUTPUT).

Input Connections

Connect the input cable from the external amplifier to the accessory board as follows:

1. Connect the external amplifier LEFT CH INPUT to J2 (LEFT CH AUX. OUTPUT).
2. Connect the external amplifier RIGHT CH INPUT to J4 (RIGHT CH AUX. OUTPUT).

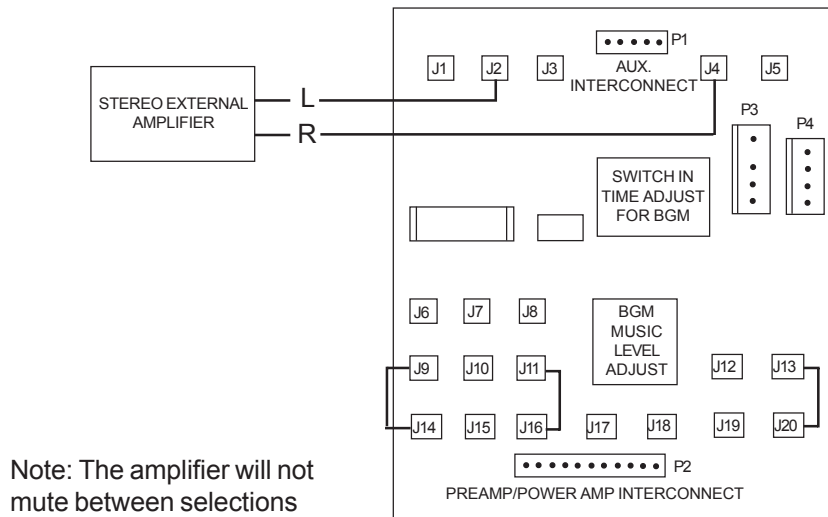

Note: The amplifier will not mute between selections

FIGURE 11 - STEREO EXTERNAL AMPLIFIER CONNECTIONS
(INDEPENDENT OF JUKEBOX VOLUME)

External Mono Amplifier Connection - No Juke Control

To drive extra speaker loads with an external monaural amplifier, use this configuration if you wish to use the volume and tone controls of the external amplifier.

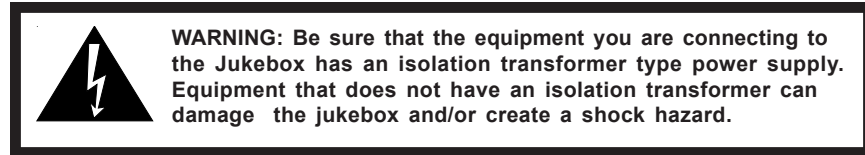

Instructions

Cables and Jumpers

Obtain a shielded audio cable long enough to reach between the external amplifier and the amplifier accessory board.

This configuration requires all three jumpers supplied with the accessory board. Connect these jumpers between:

1. J9 (LEFT CH POWERAMP INPUT) and J14 (INVERTER OUTPUT).
2. J13 (RIGHT CH POWERAMP INPUT) and J20 (RIGHT CH PREAMP OUTPUT).
3. J11 (INVERTER INPUT) and J16 (LH CH OUTPUT).

Input Connections

Connect the input cable from the external amplifier to the accessory board as follows:

1. Connect the external amplifier INPUT to J3 (AUX. OUTPUT MONO).

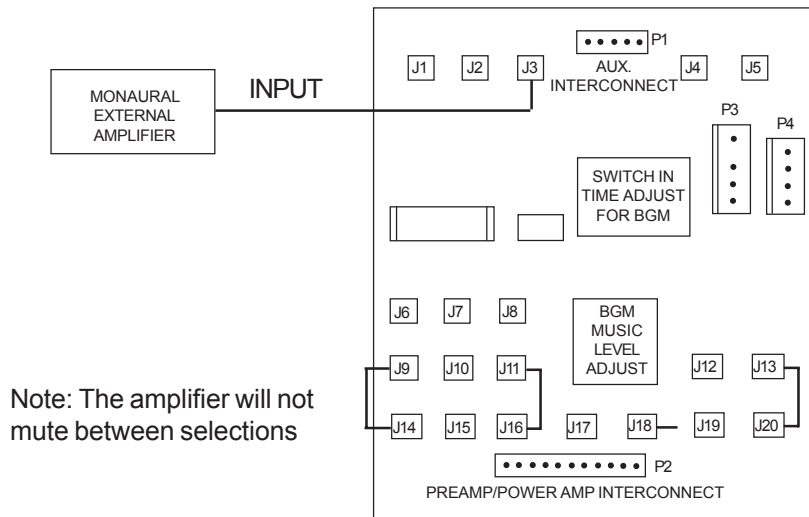

FIGURE 12 - MONO EXTERNAL AMPLIFIER CONNECTIONS
(INDEPENDENT OF JUKEBOX VOLUME)

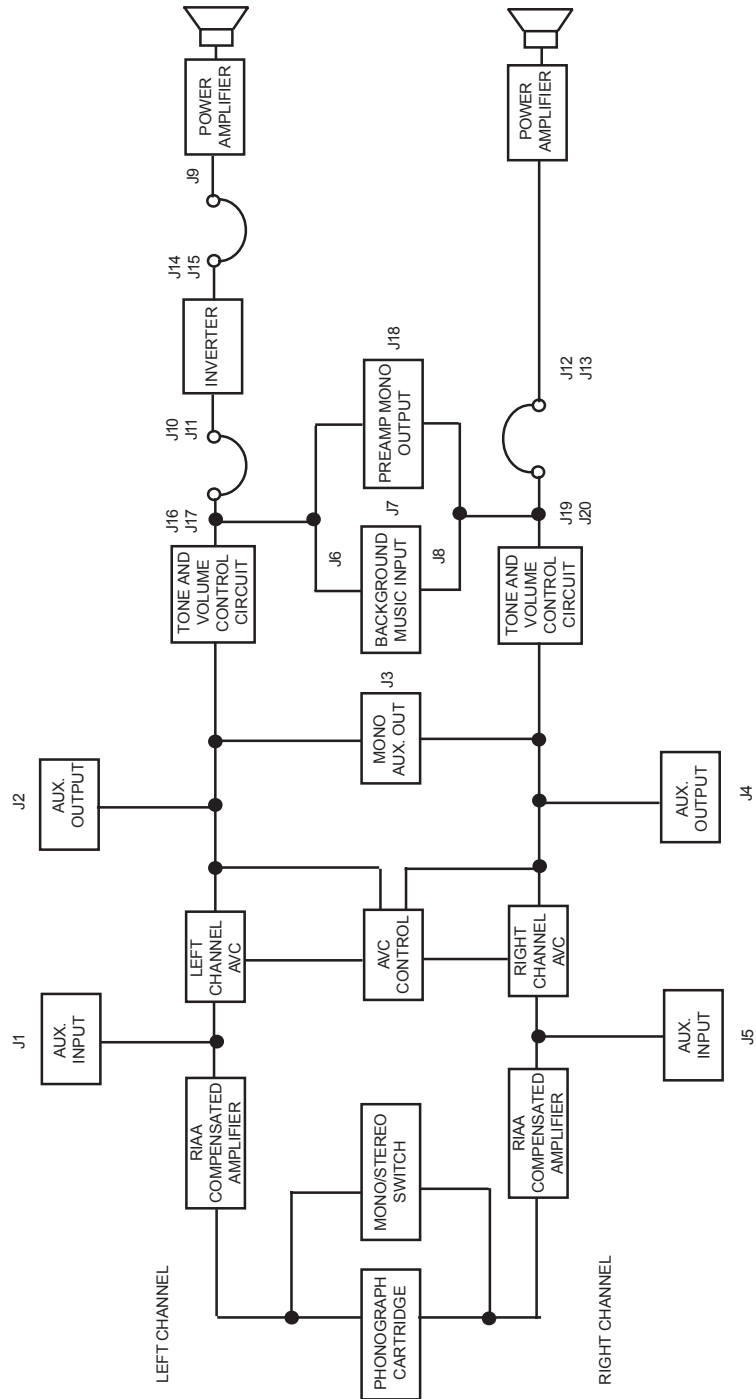

FIGURE 13 - ACCESSORY BOARD BLOCK DIAGRAM

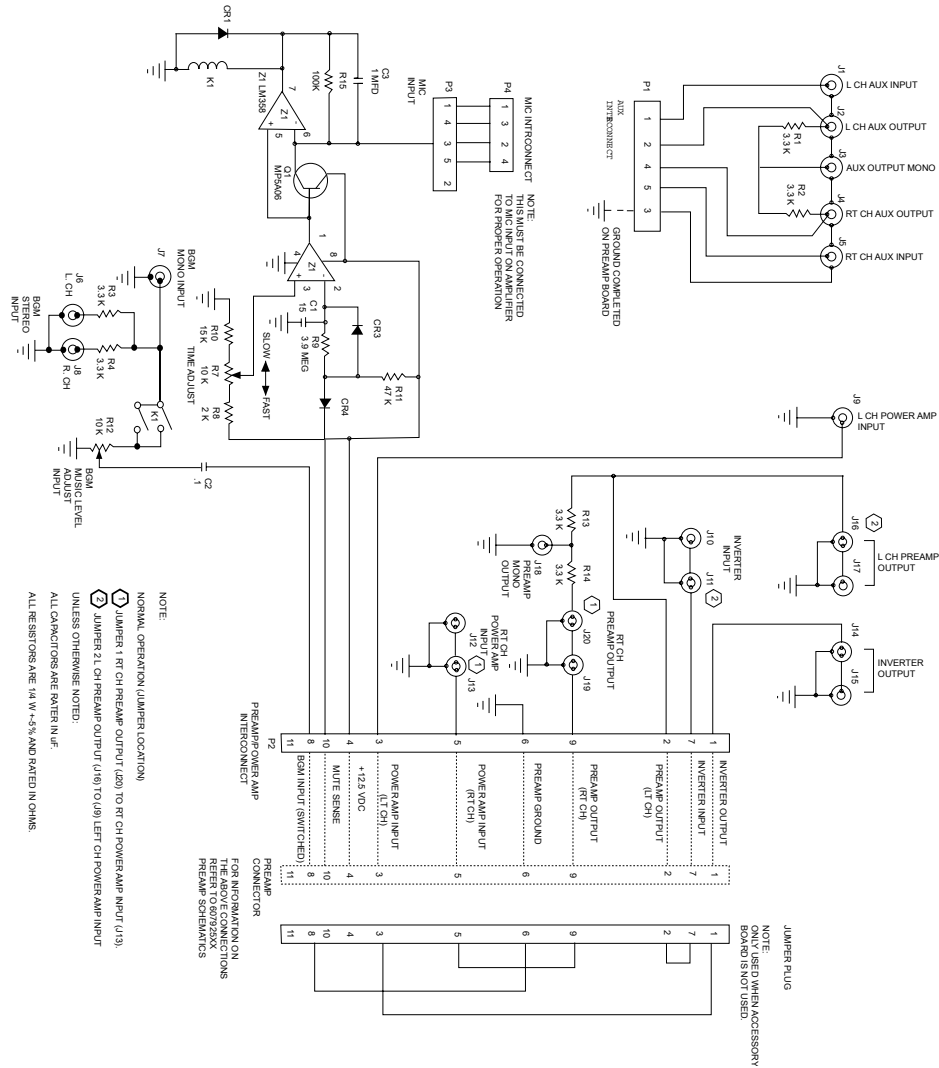

FIGURE 14 - ACCESSORY BOARD SCHEMATIC DIAGRAM

**COMPONENT LIST FOR CIRCUIT BOARD ASSEMBLY -
PREAMP ACCESSORY BOARD**

C1	Capacitor - Electrolytic	(15 MFD)
C2	Capacitor - Mono Ceramic	(.1 MFD)
C3	Capacitor - Mono Ceramic	(1 MFD)
CR1	Diode - Silicon	
CR2	Not Used	
CR3	Diode - Silicon	
CR4	Diode - Silicon	
CR5	Not Used	
J1 - J20	Receptacle - P.C.	
K1	Relay - Reed (P.C. 12/15V)	
P1	Wafer - Non-Polarizing	(5 CKT)
P2	Wafer - Polarizing	(11 CKT)
P3	Wafer - Polarizing	(5 CKT)
P4	Wafer - Polarizing	(4 CKT)
Q1	Transistor - Silicone	(MPS A06)
R1	Resistor - Carbon 3.3 K	(1/4 W, 5%)
R2	Resistor - Carbon 3.3 K	(1/4 W, 5%)
R3	Resistor - Carbon 3.3 K	(1/4 W, 5%)
R4	Resistor - Carbon 3.3 K	(1/4 W, 5%)
R5	Not Used	
R6	Not Used	
R7	Potentiometer (10 K - 20%)	
R8	Resistor - Carbon 2 K	(1/4 W, 5%)
R9	Resistor - Carbon 3.9 MEG	(1/4 W, 5%)
R10	Resistor - Carbon 15 K	(1/4 W, 5%)
R11	Resistor - Carbon 47 K	(1/4 W, 5%)
R12	Potentiometer (10 K, 20%)	
R13	Resistor - Carbon 3.3 K	(1/4 W, 5%)
R14	Resistor - Carbon 3.3 K	(1/4 W, 5%)
R15	Resistor - Carbon 100 K	(1/4 W, 5%)
Z1	IC - Dual OP-AMP	(LM358)
J1	Jumper - 22 AWG Solid	

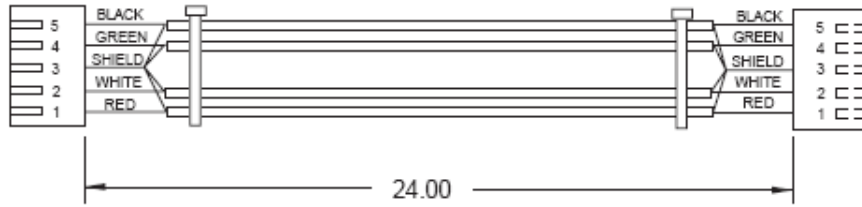

FIGURE 15 - EC1942-01 HARNESS ASSEMBLY -
ACCESSORY BOARD TO PREAMPAUX INPUT

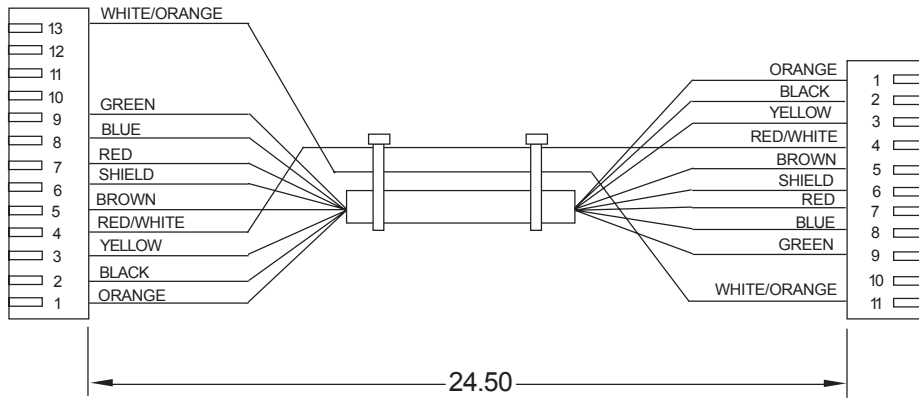

FIGURE 16 - EC1939-01 HARNESS ASSEMBLY -
PREAMP/ACCESSORY BOARD INTERCONNECT

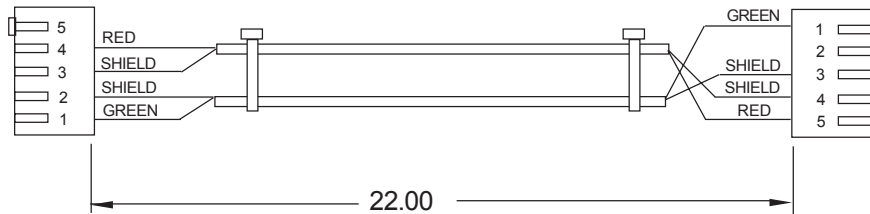

FIGURE 17 - EC1940-01 HARNESS ASSEMBLY -
ACCESSORY BOARD TO PREAMP MIC INPUT

INSTALLATION TIPS AND TECHNIQUES

If you are having difficulty with your accessory board installation, review the following list of installation tips for the problem that matches or nearly matches your situation.

Excessive Hum

The primary cause of hum is poor grounding. Make sure that each audio line connecting the accessory board to the added equipment has a good ground at both ends. If the wires are soldered, check for cold solder connection. If the ground connections are crimped, look for an incomplete or forgotten crimp.

If the audio grounding is not the fault, you might have a voltage difference between the jukebox and the added equipment. To check for this condition, unplug one cable at a time, and measure the voltage between the ground on the cable and the Jukebox ground. You should not be able to measure any AC or DC voltage between the two units. If you do measure any voltage, you must isolate the added equipment from the power line. Sometimes this can be avoided by reversing the 120 volt plug (2-prong plugs only).

If the added equipment is causing the hum and the hum is due to a voltage differential, but the 120 plug on the equipment has a 3-prong plug, we do not advise using an isolation plug to correct the problem. In this situation, it is suggested that you have a competent repair center make the needed repairs.

Noise Between Audio Selections

This condition can exist if you have chosen a configuration which does not allow the jukebox mute circuit to quiet the jukebox between selections. If this condition exists, consult a competent electronics technician or engineer for the circuit necessary to mute the specific added equipment and jukebox combination.

Cross talk

Cross talk can exist when an external preamp is used between the tone and volume circuits (J16, J17 and J19, J20) and the power amplifier (J10, J11 and J12, J13). Cross talk will exist because R13 and R14 (see schematic - Figure 14) will "mix" the left and right channel signals.

To correct this problem, make a shorting plug (connect the center of the plug to the case) and plug it into J18.

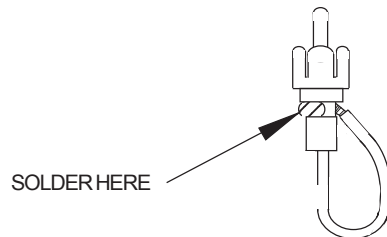

FIGURE 18 - SHORTING PLUG

MOD BOX AMPLIFIER ACCESSORY BOARD CONNECTIONS
PM0564-03