



**Megatouch  
FORCE 2009™ Edition  
Hard Drive Upgrade**

Visit the Merit Entertainment Web site  
<http://www.meritgames.com>



PM0513-13



## Table of Contents

---

<b>Hard Drive Removal and Installation .....</b>	<b>p. 1-13</b>
Classic .....	p. 2
Elite .....	p. 3
Radion .....	p. 4
eVo, eVo Walleette and Elite Edge .....	p. 5
Vibe .....	p. 6
Fusion .....	p. 7
Upright without Coin Door .....	p. 8
Upright with Coin Door .....	p. 9-10
Combo Jukebox .....	p. 11-12
Maxx to Force-Converted Games .....	p. 13
<b>Security Key Installation .....</b>	<b>p. 14</b>
<b>Software License Agreements .....</b>	<b>p. 15-20</b>
English .....	p. 15-16
French .....	p. 17-18
German .....	p. 19-20

---

© 2008 Merit Entertainment

Force 2009, Megatouch, MegaNet and TournaMAXX are registered trademarks of Merit Entertainment.

Reproduction of this manual, in any form or by any means, is strictly forbidden without the written permission of Merit Entertainment.

## Megatouch Force 2009™ Hard Drive Upgrade

**CONTENTS:**

QTY	PART NUMBER	DESCRIPTION
1	SB0446-09	FORCE 2009 HARD DRIVE ASSEMBLY
<b>FOR KITS WITH SECURITY KEY ONLY</b>		
1	SA3570-XX	FORCE 2009 KEY

Follow the installation instructions for your game type.

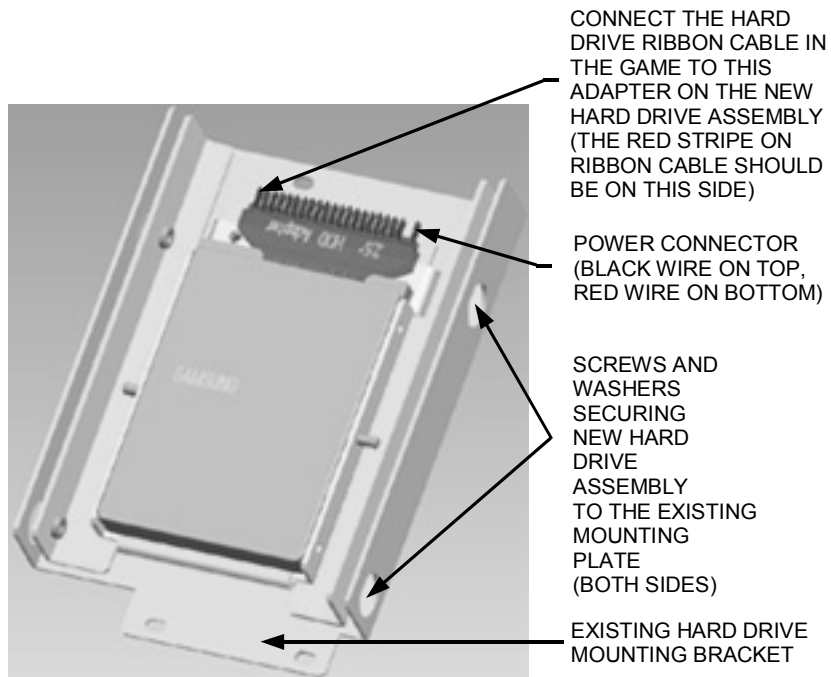

FIGURE 1 - NEW HARD DRIVE ASSEMBLY

## Force Classic Games

### Hard Drive Removal

1. If you are connected to TournaMAXX or TournaCHAMP, you must perform an **Update From Server** before removing the hard drive so that no information is deleted.
2. Turn off and unplug the game.
3. Unlock and open the lid.
4. Remove the screw securing the hard drive mounting plate to the game and remove the hard drive assembly as much as the cabling will allow. See Figure 2.
5. Disconnect the 4-pin power connector and the ribbon cable from the hard drive, then remove the hard drive assembly from the game.
6. Remove the 4 screws and shoulder washers securing the hard drive to the mounting plate. See Figure 2.

### Hard Drive Installation

7. Fasten the new hard drive assembly to the existing mounting plate with the 4 screws and shoulder washers. See Figure 1.

8. Connect the 4-pin power connector in the game to the mating 4-pin connector attached to the hard drive adapter. See Figure 1.
9. Carefully reconnect the ribbon cable in the game to the new hard drive as shown in Figure 1. The red stripe on the cable should be on the opposite side as the power connector. You may need to create extra slack in the cable in order to connect it.
10. Fasten the hard drive mounting plate to the game with the mounting screw. See Figure 2.
11. Continue with **Security Key Installation** if you are installing a security key.
12. Close and lock the lid.
13. Plug in and turn on the game. The game will reboot twice to configure the hardware. When prompted, perform a touchscreen calibration.
14. If you are connected to TournaMAXX or TournaCHAMP, you must re-enter the dial-in settings, make the initial call into the server and then perform two **Updates From Server**. Refer to the MegaNet® manual for information.

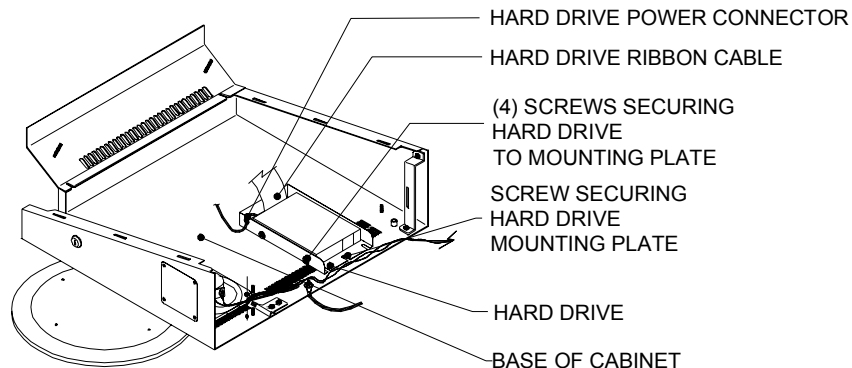

FIGURE 2 - FORCE CLASSIC CHASSIS

## Force Elite Games

### Hard Drive Removal

1. If you are connected to TournaMAXX or TournaCHAMP, you must perform an **Update From Server** before removing the hard drive so that no information is deleted.
2. Turn off and unplug the game.
3. Unlock and open the rear door.
4. Remove the screw securing the hard drive mounting plate (see Figure 3) and slide the hard drive assembly towards the back of the unit.
5. Lift the hard drive assembly out of the game until you're able to disconnect the 4-pin power connector and the hard drive ribbon cable from the rear of the hard drive.
6. Remove the 4 screws and shoulder washers fastening the hard drive to the mounting plate.

### Hard Drive Installation

7. Fasten the new hard drive assembly to the existing mounting plate with the 4 screws and shoulder washers. See Figure 1.

8. Connect the 4-pin power connector in the game to the mating 4-pin connector attached to the hard drive adapter. See Figure 1.
9. Carefully reconnect the ribbon cable in the game to the new hard drive as shown in Figure 1. The red stripe on the cable should be on the opposite side as the power connector. You may need to create extra slack in the cable in order to connect it.
10. Slide the hard drive assembly into the game and fasten it with the mounting screw.
11. Continue with **Security Key Installation** if you are installing a security key.
12. Close and lock the rear door.
13. Restore power to the game. The game will reboot twice to configure the hardware. When prompted, perform a touchscreen calibration.
14. If you are connected to TournaMAXX or TournaCHAMP, you must re-enter the dial-in settings, make the initial call into the server and then perform two **Updates From Server**. Refer to the MegaNet® manual for information.

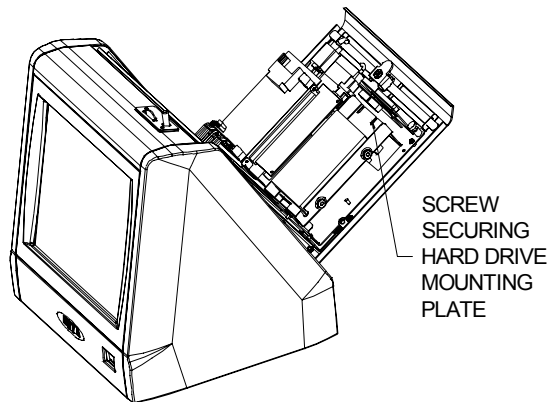

FIGURE 3- ELITE WITH REAR DOOR OPEN

## Force Radion

### Hard Drive Removal

1. If you are connected to TournaMAXX or TournaCHAMP, you must perform an **Update From Server** before removing the hard drive so that no information is deleted.
2. Turn off and unplug the game.
3. Unlock and open/remove the rear door and the left side door.
4. Locate the hard drive and remove the 2 screws securing the hard drive mounting bracket to the game (see Figure 4), then remove the hard drive assembly until you're able to disconnect the hard drive power connector and the motherboard ribbon cable.
5. Remove the 4 screws and shoulder washers fastening the hard drive to the mounting plate.

### Hard Drive Installation

6. Fasten the new hard drive assembly to the existing mounting plate with the 4 screws and shoulder washers. See Figure 1.

7. Connect the 4-pin power connector in the game to the mating 4-pin connector attached to the hard drive adapter. See Figure 1.
8. Carefully reconnect the ribbon cable in the game to the new hard drive as shown in Figure 1. The red stripe on the cable should be on the opposite side as the power connector. You may need to create extra slack in the cable in order to connect it.
9. Replace the hard drive assembly in the game and fasten it with the 2 screws. See Figure 4.
10. Continue with **Security Key Installation** if you are installing a security key.
11. Close/replace and lock the rear door and the side door.
12. Restore power to the game. The game will reboot twice to configure the hardware. When prompted, perform a touchscreen calibration.
13. If you are connected to TournaMAXX or TournaCHAMP, you must re-enter the dial-in settings, make the initial call into the server and then perform two **Updates From Server**. Refer to the MegaNet® manual for information.



FIGURE 4 - SIDE VIEW OF RADION GAME

## FORCE eVo, eVo Wallete and Elite Edge

### Hard Drive Removal

1. If you are connected to TournaMAXX or TournaCHAMP, you must perform an **Update From Server** before removing the hard drive so that no information is deleted.
2. Turn off and unplug the game.
3. Unlock and open the CPU section.
4. Remove the 3 screws securing the hard drive mounting bracket to the game (the top screw also secures the strain relief cord, so you must support the front of the game during removal). Then remove the hard drive assembly until you're able to disconnect the hard drive power connector and the hard drive ribbon cable running to the motherboard. See Figure 5.
5. Remove the 4 screws and shoulder washers fastening the hard drive to the mounting plate. See Figure 5.

### Hard Drive Installation

6. Fasten the new hard drive assembly to the existing mounting plate with the

- 4 screws and shoulder washers. See Figure 1.
7. Connect the 4-pin power connector in the game to the mating 4-pin connector attached to the hard drive adapter. See Figure 1.
8. Carefully reconnect the ribbon cable in the game to the new hard drive as shown in Figure 1. The red stripe on the cable should be on the opposite side as the power connector. You may need to create extra slack in the cable in order to connect it.
9. Fasten the hard drive mounting plate to the game with the three screws. See Figure 5.
10. Continue with **Security Key Installation** if you are installing a security key.
11. Close and lock the CPU section.
12. Plug in and turn on the game. The game will reboot twice to configure the hardware. When prompted, perform a touchscreen calibration.
13. If you are connected to TournaMAXX or TournaCHAMP, you must re-enter the dial-in settings, make the initial call into the server and then perform two **Updates From Server**. Refer to the MegaNet® manual for information.

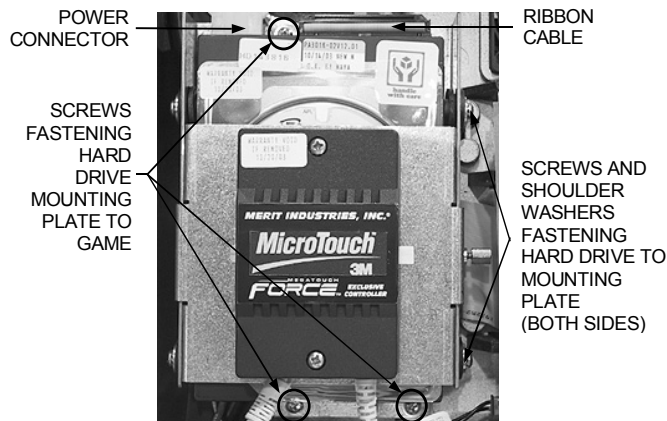

FIGURE 5 - HARD DRIVE - SCREWS FASTENING HARD DRIVE MOUNTING PLATE



## VIBE Games

### Hard Drive Removal

1. If you are connected to TournaMAXX or TournaCHAMP, you must perform an **Update From Server** before removing the hard drive so that no information is deleted.
2. Turn off and unplug the game.
3. Unlock the lock on the processor cover and loosen the 3 screws on either side of the cover. Slide the cover away from the connector side of the processor and lift the cover off of the unit.
4. Remove the 3 screws securing the hard drive to the processor (see Figure 6).
5. Disconnect the I/O and audio harness, then remove the hard drive assembly until you're able to disconnect the hard drive ribbon cable and hard drive power connector. See Figure 6.
6. Remove the 4 screws and shoulder washers fastening the hard drive to the mounting plate. See Figure 6.
7. Fasten the new hard drive assembly to the existing mounting plate with the 4 screws and washers. See Figure 1.
8. Connect the 4-pin power connector in the game to the mating 4-pin connector attached to the hard drive adapter. See Figure 1.
9. Carefully reconnect the ribbon cable in the game to the new hard drive as shown in Figure 1. The red stripe on the cable should be on the opposite side as the power connector. You may need to create extra slack in the cable in order to connect it.
10. Fasten the hard drive assembly to the processor with the 3 screws (see Figure 6).
11. Continue with **Security Key Installation** if you are installing a security key.
12. Replace the processor cover and secure it with the 6 screws.
13. Plug in and turn on the game. The game will reboot twice to configure the hardware. When prompted, perform a touchscreen calibration.
14. If you are connected to TournaMAXX or TournaCHAMP, you must re-enter the dial-in settings, make the initial call into the server and then perform two **Updates From Server**. Refer to the MegaNet® manual for information.

### Hard Drive Installation

7. Fasten the new hard drive assembly to the existing mounting plate with the 4 screws and washers. See Figure 1.

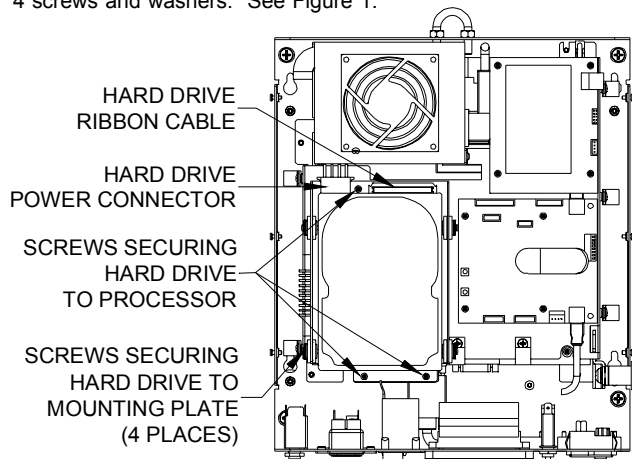

FIGURE 6 - TOP VIEW OF PROCESSOR WITH COVER REMOVED

## Force Fusion Games

### Hard Drive Removal

1. If you are connected to TournaMAXX or TournaCHAMP, you must perform an **Update From Server** before removing the hard drive so that no information is deleted.
2. Turn off and unplug the game.
3. Unlock and open the bezel.  
*Games with electronic boxes:* Remove the 2 screws fastening the electronics box cover and remove the cover.
4. Locate the hard drive. It will either be mounted to the electronics box cover or against the back wall of the game. Remove the 3 screws or standoffs securing the hard drive mounting bracket to the cover or the game, then remove the hard drive assembly until you're able to disconnect the hard drive power connector and hard drive ribbon cable.
5. Remove the 4 screws and shoulder washers fastening the hard drive to the mounting plate (see Figure 7).

### Hard Drive Installation

6. Fasten the new hard drive assembly to the existing mounting plate with the 4 screws and shoulder washers. See Figure 1.

7. Connect the 4-pin power connector in the game to the mating 4-pin connector attached to the hard drive adapter. See Figure 1.
8. Carefully reconnect the ribbon cable in the game to the new hard drive as shown in Figure 1. The red stripe on the cable should be on the opposite side as the power connector. You may need to create extra slack in the cable in order to connect it.
9. Fasten the hard drive assembly to the electronics box cover or game with the 3 screws or standoffs. See Figure 7.
10. Continue with **Security Key Installation** if you are installing a security key.
11. Close and lock the bezel.  
*Games with electronic boxes:* Replace the electronics box cover and fasten it with the 2 screws.
12. Plug in and turn on the game. The game will reboot twice to configure the hardware. When prompted, perform a touchscreen calibration.
13. If you are connected to TournaMAXX or TournaCHAMP, you must re-enter the dial-in settings, make the initial call into the server and then perform two **Updates From Server**. Refer to the MegaNet® manual for information.



FIGURE 7 - FUSION HARD DRIVE

## Force Upright without Coin Door

### Hard Drive Removal

1. If you are connected to TournaMAXX or TournaCHAMP, you must perform an **Update From Server** before removing the hard drive so that no information is deleted.
2. Turn off and unplug the game.
3. Unlock and open the front bezel.
4. Slide the CPU shelf into its service position to access the hard drive.
5. Remove the screw securing the hard drive mounting plate to the shelf (see Figure 8).
6. Remove the 4 screws and shoulder washers fastening the hard drive to the mounting plate. See Figure 8.
7. Disconnect the hard drive ribbon cable and the hard drive power connector from the hard drive.

### Hard Drive Installation

8. Fasten the new hard drive assembly to the existing mounting plate with the 4 screws and shoulder washers. See Figure 1.

9. Connect the 4-pin power connector in the game to the mating 4-pin connector attached to the hard drive adapter. See Figure 1.
10. Carefully reconnect the ribbon cable in the game to the new hard drive as shown in Figure 1. The red stripe on the cable should be on the opposite side as the power connector. You may need to create extra slack in the cable in order to connect it.
11. Fasten the hard drive assembly to the CPU shelf with the mounting screw (see Figure 8).
12. Continue with **Security Key Installation** if you are installing a security key.
13. Slide the CPU shelf back into the game.
14. Close and lock the front bezel.
15. Plug in and turn on the game. The game will reboot twice to configure the hardware. When prompted, perform a touchscreen calibration.
16. If you are connected to TournaMAXX or TournaCHAMP, you must re-enter the dial-in settings, make the initial call into the server and then perform two **Updates From Server**. Refer to the MegaNet® manual for information.

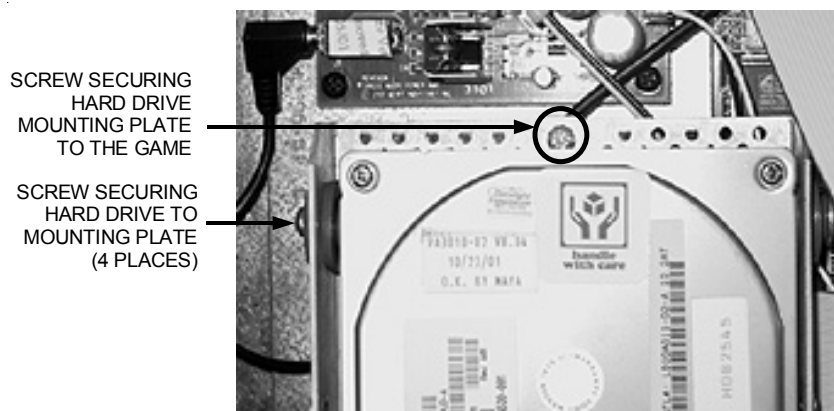

FIGURE 8 - HARD DRIVE MOUNTING PLATE ATTACHED TO CPU SHELF

## Force Upright with Coin Door

### Hard Drive Removal

1. If you are connected to TournaMAXX or TournaCHAMP, you must perform an **Update From Server** before removing the hard drive so that no information is deleted.
2. Turn off and unplug the game.
3. Unlock and open the front door to access the electronics shelf.
4. The I/O board assembly will need to be moved aside in order to access the hard drive. Remove the 2 screws securing the I/O board mounting plate to the hard drive mounting plate (see Figure 9).
5. Remove the screw securing the hard drive mounting plate to the game (see Figure 10).
6. Disconnect the hard drive ribbon cable and the hard drive power connector from the hard drive.
7. Remove the 4 screws and shoulder washers fastening the hard drive to the mounting plate (see Figure 9) and remove the hard drive.

### Hard Drive Installation

8. Fasten the new hard drive assembly to the existing mounting plate with the 4 screws and shoulder washers. See Figure 1.
9. Connect the 4-pin power connector in the game to the mating 4-pin connector attached to the hard drive adapter. See Figure 1.
10. Carefully reconnect the ribbon cable in the game to the new hard drive as shown in Figure 1. The red stripe on the cable should be on the opposite side as the power connector. You may need to create extra slack in the cable in order to connect it.
11. Fasten the hard drive mounting plate to the game with the mounting screw (see Figure 10).
12. Fasten the I/O board mounting plate to the hard drive mounting plate with the 2 screws (see Figure 9).
13. Continue with **Security Key Installation** if you are installing a security key.
14. Close and lock the front door.
15. Plug in and turn on the game. The game will reboot twice to configure the hardware. When prompted, perform a touchscreen calibration.
16. If you are connected to TournaMAXX or TournaCHAMP, you must re-enter the dial-in settings, make the initial call into the server and then perform two **Updates From Server**. Refer to the MegaNet® manual for information.

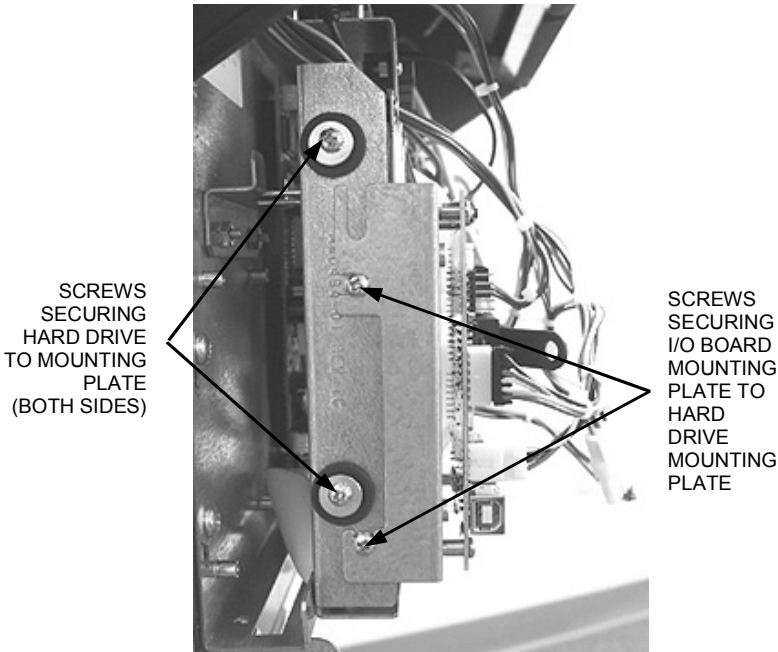

FIGURE 9 - SIDE VIEW OF HARD DRIVE



FIGURE 10 - TOP VIEW OF I/O BOARD AND HARD DRIVE

## Megatouch Combo Jukebox

### Hard Drive Removal

1. If you are connected to TournaMAXX or TournaCHAMP, you must perform an **Update From Server** before removing the hard drive so that no information is deleted.
2. Turn off the main power switch on the outside of the game.
3. Unlock and remove the rear door, then turn off the internal power switch (located above the cooling fan on the left side). Then unplug the game.
4. Remove the screw securing the hard drive mounting plate to the electronics tray (see Figure 11).
5. The I/O board assembly will need to be moved aside in order to access the hard drive. Remove the 2 screws securing the I/O board mounting plate to the hard drive mounting plate. See Figure 11.
6. Disconnect the power connector and the ribbon cable from the hard drive (see Figure 11).
7. Remove the 4 screws and shoulder washers fastening the hard drive to the hard drive mounting plate. See Figure 11.

### Hard Drive Installation

8. Fasten the new hard drive assembly to the existing mounting plate with the 4 screws and shoulder washers. See Figure 1.
9. Connect the 4-pin power connector in the game to the mating 4-pin connector attached to the hard drive adapter. See Figure 1.
10. Carefully reconnect the ribbon cable in the game to the new hard drive as shown in Figure 1. The red stripe on the cable should be on the opposite side as the power connector. You may need to create extra slack in the cable in order to connect it.
11. Resecure the I/O board mounting plate to the hard drive assembly with the 2 screws (see Figure 11).
12. Fasten the hard drive and I/O board assemblies to the electronics tray with the mounting screw (see Figure 11).
13. Continue with **Security Key Installation** if you are installing a security key.
14. Plug in the game, then turn on the internal power switch and replace and lock the rear door.
15. Turn on the main power switch on the outside of the game. The game will reboot twice to configure the hardware. When prompted, perform a touchscreen calibration.
16. If you are connected to TournaMAXX or TournaCHAMP, you must re-enter the dial-in settings, make the initial call into the server and then perform two **Updates From Server**. Refer to the MegaNet® manual for information.

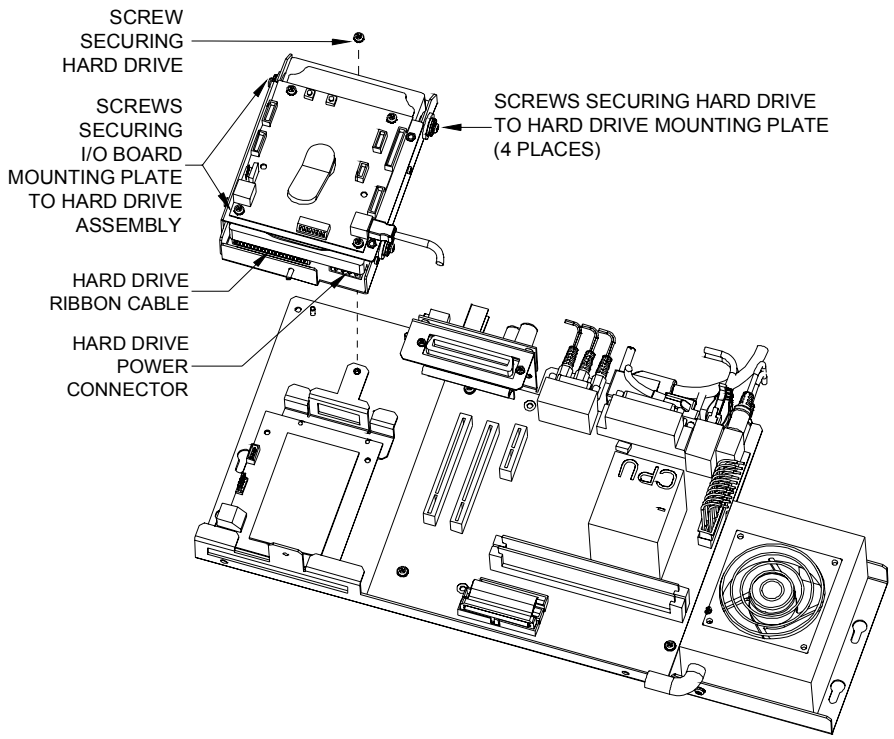

FIGURE 11 - COMBO JUKEBOX ELECTRONICS SHELF

## Maxx to Force-Converted Games

### Hard Drive Removal

1. If you are connected to TournaMAXX or TournaCHAMP, you must perform an **Update From Server** before removing the hard drive so that no information is deleted.
2. Turn off and unplug the game.
3. Unlock and open the CPU section door.
4. Remove the 3 screws or standoffs securing the hard drive mounting bracket to the electronics tray, then remove the hard drive assembly until you're able to disconnect the hard drive power connector and hard drive ribbon cable.
5. Remove the 4 screws and shoulder washers fastening the hard drive to the mounting plate (see Figure 12).

### Hard Drive Installation

6. Fasten the new hard drive assembly to the existing mounting plate with the 4 screws and shoulder washers. See Figure 1.

7. Connect the 4-pin power connector in the game to the mating 4-pin connector attached to the hard drive adapter. See Figure 1.
8. Carefully reconnect the ribbon cable in the game to the new hard drive as shown in Figure 1. The red stripe on the cable should be on the opposite side as the power connector. You may need to create extra slack in the cable in order to connect it.
9. Fasten the hard drive assembly to the electronics tray with the 3 screws or standoffs. See Figure 12.
10. Continue with **Security Key Installation** if you are installing a security key.
11. Close and lock the CPU section.
12. Plug in and turn on the game. The game will reboot twice to configure the hardware. When prompted, perform a touchscreen calibration.
13. If you are connected to TournaMAXX or TournaCHAMP, you must re-enter the dial-in settings, make the initial call into the server and then perform two **Updates From Server**. Refer to the MegaNet® manual for information.



FIGURE 12 - HARD DRIVE IN MAXX TO FORCE CONVERTED GAMES



## **Security Key Installation** (for kits with security keys)

1. Locate the security key (the button-shaped disc with the spoon handle) on the I/O board or control board.
2. Remove the existing security key from the board and replace it with the supplied security key.
3. Close and lock the CPU section door of the game and restore power to the game. The game will reboot twice to configure the hardware. When prompted, perform a touchscreen calibration.
4. If you are connected to TournaMAXX or TournaCHAMP, you must re-enter the dial-in settings, make the initial call into the server and then perform two **Updates From Server**. Refer to the MegaNet® manual for information.

## Merit Industries, Inc. Software License Agreement

Merit Industries, Inc. ("Licensor") is willing to license the enclosed software to you only if you accept all of the terms in this license agreement ("Agreement").

### Ownership of the Software

1. The enclosed Merit® product, which may include but is not limited to the Megatouch® software program ("Software") and the accompanying written materials are owned by Licensor and are protected by United States copyright laws, patent laws and other intellectual property laws, by laws of other nations, and by international treaties.

### Restrictions on Use and Transfer

2. If this Software package contains multiple media types (such as CD's, flash cards, hard drives, etc), then you may use only the type of media appropriate for your Machine. You may not use the other media types on another Machine, or transfer, or assign them to another user except as part of the permanent transfer of the Software and all written materials (as provided for below in paragraph 4).
3. You may make one copy of the software for backup purposes only. You may not copy or make backup copies of any software security key or software security device under any circumstances.
4. You may permanently transfer the right to use the Software and accompanying written materials (including the most recent update and all prior versions) if you retain no copies and the transferee agrees in writing to be bound by the terms of this Agreement. Such a transfer of this license to another party immediately terminates your license. You may not otherwise transfer or assign the right to use the Software, except as stated in this paragraph.
5. You may not operate or allow the operation of the Software at locations where the operation of such Software does not comply with all local, state, and other governmental body laws and regulations. You agree to not use or permit the use of the Software in violation of any U.S. Federal, state, or local laws or regulations or any foreign law or regulation, including laws regarding gaming, gambling or intellectual property rights in or concerning the Software.
6. You may not modify, adapt, translate, reverse engineer, decompile, disassemble the Software or create derivative works from the Software or any component thereof; nor may you remove, modify or hide or otherwise make unreadable or non-viewable any notice, legend, advice, watermark or other designation contained on the Software, component thereof, or output therefrom.
7. You agree that the Software and the authorship, systems, ideas, inventions methods of operation, documentation and other information contained therein, and all versions, modifications and adaptations thereto are proprietary intellectual properties of Licensor and are protected by civil and criminal law, and by copyright, trade secret, trademark and the patent laws of the United States and other countries.

### Limited Warranty

8. Licensor warrants, solely for your benefit, that the Software will function in material conformity, with its accompanying documentation for a period outlined in Licensor's standard product warranty period after your receipt of the Software.

### Licensor's Obligations Under Warranty

9. Licensor's sole obligation under the aforesaid warranty shall be to utilize commercially reasonable efforts to correct or modify such portion of the Software as to make it materially conform with the applicable documentation.

#### Grant Of License

10. Licensor grants to you a limited, non-exclusive license to distribute and/or use one copy of the Software on a single Merit ("Machine") accompanied by a single licensor factory authorized security key. Licensor reserves the right to update versions of the software and the content to the Machine as deemed appropriate by the Licensor. You are entrusted to maintain and protect your single licensor factory authorized security key, password, or other identification from being utilized by any third party, and you agree to be responsible for any use of the Software provided herein by a third party utilizing your identification. Licensor maintains the right to immediately terminate your License for reasons related to misuse or other non-conformity with the rules expressed herein. While Licensor does not routinely inspect Machines, Licensor also reserves the right to inspect or audit the Software from time to time in Licensor's sole discretion. To the extent that Licensor's access to the Software requires that Licensor also gain access to a Machine in which the Software is installed, you agree to promptly provide Licensor, when requested, with permission and aid in Licensor gaining access to the Machine.

#### Disclaimers

11. EXCEPT AS PROVIDED IN THE SECTION ENTITLED "LIMITED WARRANTY", LICENSOR MAKES NO OTHER PROMISES, REPRESENTATIONS OR WARRANTIES, WHETHER EXPRESSED OR IMPLIED, REGARDING OR RELATING TO THE SOFTWARE OR CONTENT THEREIN OR TO ANY OTHER MATERIAL FURNISHED OR PROVIDED TO YOU PURSUANT TO THIS AGREEMENT OR OTHERWISE AND LICENSOR SPECIFICALLY DISCLAIMS ALL IMPLIED WARRANTIES OF MERCHANTABILITY AND FITNESS FOR A PARTICULAR PURPOSE WITH RESPECT TO SAID MATERIALS OR THE USE THEREOF. TO THE MAXIMUM EXTENT ALLOWABLE BY LAW THE UNIFORM COMMERCIAL CODE OR OTHER UNIFORM LAWS SHALL NOT APPLY TO THIS AGREEMENT.

#### Limitation on Liability

12. IN NO EVENT SHALL LICENSOR BE LIABLE UNDER ANY CLAIM, DEMAND OR ACTION ARISING OUT OF OR RELATING TO THE SOFTWARE, ITS USE, INSTALLATION OR LICENSOR'S PERFORMANCE OR LACK THEREOF UNDER THIS AGREEMENT FOR ANY SPECIAL, INDIRECT, INCIDENTAL, EXEMPLARY OR CONSEQUENTIAL DAMAGES, WHETHER OR NOT LICENSOR HAS BEEN ADVISED OF THE POSSIBILITY OF SUCH CLAIM, DEMAND OR ACTION. IN ADDITION, WITHOUT LIMITING THE FOREGOING, IN ALL EVENTS THE REMEDIES AVAILABLE TO YOU SHALL BE LIMITED TO THE AMOUNT PAID BY YOU TO LICENSOR FOR THE SOFTWARE.
13. IN NO EVENT WILL LICENSOR BE LIABLE TO YOU FOR DAMAGES, INCLUDING ANY LOSS OF PROFITS, LOST SAVINGS, OR OTHER INCIDENTAL OR CONSEQUENTIAL DAMAGES ARISING OUT OF YOUR USE, MISUSE, BREACH OF THIS AGREEMENT OR INABILITY TO USE THE SOFTWARE.

#### General

14. The validity and construction of this Agreement and of the rights and obligations herein shall be determined and governed by the laws of the State of New York. By accepting the terms of this Agreement, you acknowledge and accept that the courts of New York, New York shall have exclusive jurisdiction and venue regarding any disputes arising with regard to this Agreement or arising out of activity or misuse of the Software.
15. Merit, in its sole discretion, may assign this agreement or any of its rights and obligations hereunder.
16. If you have any questions concerning this Agreement or wish to contact Licensor for any reason, please write: Merit Industries, Inc., 155 Rittenhouse Circle, Bristol, PA 19007, USA.

## **Contrat de licence de logiciel de Merit Industries, Inc.**

Merit Industries, Inc. (ci-après le "Concédant") est disposé à vous accorder la licence d'utilisation du logiciel ci-inclus, à condition que vous vous engagiez à respecter tous les termes, clauses et conditions du présent contrat de licence (Contrat).

### **Droit de Propriété**

1. Le produit Merit ci-joint contenant, mais ne s'y limitant pas, le logiciel Megatouch™ (ci-après le "logiciel") et toute la documentation écrite, restent la propriété du Concédant et sont protégés par : les lois de droits d'auteur des Etats-Unis, les lois s'appliquant aux brevets déposés et à la propriété intellectuelle, ainsi que par celles des autres pays et les traités internationaux.

### **Restriction d'Utilisation et Transfert**

2. Si le présent logiciel comprend plusieurs types de composants (tels que CD-ROM, cartes flash, disques durs, etc), vous ne pouvez utiliser que ceux qui conviennent à votre appareil. Il est strictement interdit de les utiliser sur un autre appareil, les transférer -ou les céder à un autre utilisateur, sauf en cas de transfert permanent du logiciel et de toute la documentation écrite (comme indiqué ci-dessous au paragraphe 4).
3. Il est interdit de copier le logiciel, à l'exception d'une copie de sauvegarde. Il est aussi interdit de reproduire -ou faire des copies de sauvegarde des programmes de clé de sécurité ou autres fichiers de sécurité, quelles que soient les circonstances.
4. Vous pouvez céder en permanence à un tiers -le droit d'utiliser le LOGICIEL et toute la documentation écrite l'accompagnant, (ainsi que la plus récente mise à jour et toutes autres anciennes versions) seulement si vous n'en gardez aucune copie, et si le cessionnaire s'engage, par écrit, à respecter les termes, clauses et conditions du présent Contrat. Cette cession à un tiers met fin à votre licence immédiatement. Autrement, vous n'avez pas la permission de transférer ou d'accorder à un tiers le droit d'utiliser le présent logiciel, excepté que tel que décrit dans le présent paragraphe.
5. Il est interdit d'utiliser le présent logiciel ou de permettre son utilisation dans des emplacements où l'utilisation du présent logiciel n'est pas conforme aux lois et réglementations locales, nationales ou réglementations d'autres organismes gouvernementaux. Vous acceptez de ne pas utiliser ou d'autoriser l'utilisation du logiciel d'une manière enfreignant les lois ou réglementations s'appliquant à la propriété intellectuelle et au jeu, en vigueur aux Etats-Unis ou dans les autres pays du monde, y compris les lois de l'ensemble du logiciel.
6. Il est interdit de modifier, adapter, traduire, démonter, décompiler, désassembler le logiciel ou créer du matériel dérivé du logiciel ou de tout composant de celui-ci ; vous ne pouvez pas enlever, modifier ou cacher ou rendre illisible ou non-visible toute instruction, légende, information ou filigrane ou autre désignation qui apparaît dans le logiciel, composant dudit logiciel ou résultant dudit logiciel.
7. Vous convenez que le logiciel et les droits d'auteur, les systèmes, les idées, les inventions, les méthodes d'utilisation, la documentation et autre information incluse, ainsi que toutes les versions, modifications et adaptations qui s'y rattachent sont les propriétés intellectuelles du Concédant et sont protégées par le droit civil et pénal et par le droit d'auteur, le secret commercial, la marque déposée et le brevet aux Etats-Unis et dans les autres pays du monde.

### **Limite de Garantie**

8. Le Concédant garantit seulement à votre intention, que le logiciel permettra une utilisation conforme, avec la documentation l'accompagnant, pendant la période de temps indiquée dans la période de garantie du produit standard du Concédant, à compter de la date de livraison du logiciel.

### **Responsabilité du Concédant aux termes de la Garantie**

9. La seule obligation du Concédant aux termes de la garantie susmentionnée sera de faire tous les efforts commercialement raisonnables pour corriger ou modifier la partie du logiciel pour le rendre matériellement conforme aux spécifications de la documentation.

Concession de Licence

10. Le Concédant vous accorde le droit d'utiliser une seule copie par appareil Merit (ci-après "Appareil") accompagné d'une seule clé de sécurité autorisée en usine et fournie par le Concédant. Le Concédant se réserve le droit de mise à jour des versions du logiciel et du contenu de l'Appareil, quand il juge nécessaire de le faire. Il vous appartient également d'empêcher que les mots de passe ou autres codes et la clé de sécurité soient utilisés par un tiers. Vous acceptez d'assumer la responsabilité dans le cas de l'utilisation du logiciel par un tiers. Le Concédant se réserve le droit de résilier votre contrat de licence à tout moment dans l'éventualité d'une utilisation non-conforme aux clauses stipulées. Bien que le Concédant ne contrôle pas les appareils périodiquement, il se réserve toutefois le droit de contrôler le logiciel à tout moment et sans préavis de sa part. De surcroît, dans l'éventualité où le logiciel n'est accessible qu'à travers la machine dans laquelle il est installé, le licencié s'engage à donner libre accès au Concédant, ou ses représentants, à la machine et dans les plus brefs délais.

Exclusion de toute autre garantie

11. EXCEPTÉ COMME PRÉVU DANS LA SECTION INTITULÉE "LIMITE DE GARANTIE", LE CONCEDANT N'ASSURE AUCUNE AUTRE GARANTIE DE QUELQUE NATURE ET A QUELQUE TITRE QUE CE SOIT, EXPLICITE OU IMPLICITE, EN RAPPORT AVEC LE LOGICIEL ET LES COMPOSANTS QUI L'ACCOMPAGNENT OU, LE CAS ÉCHÉANT, TOUT SUPPORT OU MATÉRIEL FOURNI CONFORMÉMENT AU PRÉSENT CONTRAT EN PARTICULIER, LE CONCEDANT NE PEUT DONNER AUCUNE GARANTIE, DE QUELQUE NATURE QUE CE SOIT, POUR LA COMMERCIALISATION DE TOUS LES PRODUITS EN RAPPORT AVEC LE LOGICIEL OU AVEC L'UTILISATION DE CELUI-CI. DANS LA MESURE OU CELA EST PERMIS PAR LA LOI, LE CODE UNIFORME COMMERCIAL OU AUTRE LOI UNIFORME NE S'APPLIQUE PAS AU PRÉSENT CONTRAT.

Limite de Responsabilité

12. LE CONCEDANT NE SERA EN AUCUN CAS RESPONSABLE DE TOUTE RECLAMATION, DEMANDE OU ACTION RESULTANT DE OU EN RAPPORT AVEC LE LOGICIEL, SON UTILISATION OU SON INSTALLATION, OU LA PERFORMANCE OU MANQUE DE PERFORMANCE DU CONCEDANT EN VERTU DU PRÉSENT CONTRAT POUR TOUS DOMMAGES D'UNE NATURE QUI N'EST PAS PRÉSUMÉE PAR LA LOI ET QUI DOIVENT ÊTRE EXPRESSEMENT Prouvés, DOMMAGE INDIRECTS, DOMMAGES-INTERETS POUR PRÉJUDICE MORAL, QUE LE CONCEDANT AIT ÉTÉ AVISÉ OU NON DE LA POSSIBILITÉ D'UNE TELLE RECLAMATION, DEMANDE OU ACTION. DE PLUS, SANS LIMITER CE QUI PRÉCÈDE, LES DÉDOMMAGEMENTS À VOTRE DISPOSITION SERONT LIMITÉS AU MONTANT QUE VOUS AUREZ PAYÉ AU CONCEDANT POUR LE LOGICIEL.
13. LE CONCEDANT NE SERA EN AUCUN CAS RESPONSABLE : D'UNE RUPTURE DE CONTRAT, DES DOMMAGES, Y COMPRIS TOUTE PERTE DE PROFIT, PERTES D'ÉCONOMIE OU TOUS AUTRES DOMMAGES INDIRECTS OU DOMMAGES-INTERETS ACCESSOIRES DÉCOULANT DE LA MAUVAISE UTILISATION OU DE L'IMPOSSIBILITÉ D'UTILISATION DU LOGICIEL.

Dispositions Générales

14. La validité et la construction du présent Contrat et les droits et obligations ci-inclus seront déterminés et régis par les lois de l'état de New York aux États-Unis. En acceptant les dispositions du présent contrat, vous acceptez également que tous litiges ou revendications relatives seront réglés par voie d'arbitrage par un tribunal de l'état de New York, aux États-Unis.
15. Merit Industries se réserve le droit de transférer le présent Contrat à un tiers ainsi que ses droits et obligations ci-après.
16. Pour toutes questions concernant le présent Contrat -ou si vous désirez contacter le Concédant pour une raison quelconque, veuillez écrire à : Merit Industries, Inc., 155 Rittenhouse Circle, Bristol, PA 19007, États-Unis.

## Merit Industries, Inc. Softwarelizenzabkommen

Merit Industries, Inc. („Lizenzgeber“) ist nur dann bereit Ihnen eine Lizenz für die beiliegende Software zu erteilen, wenn Sie alle Bestimmungen dieses Lizenzabkommens („Abkommen“) akzeptieren.

### Eigentumsvorbehalt der Software

1. Das beiliegende Merit®-Produkt, welches das Megatouch® Softwareprogramm („Software“) beinhalten kann, aber nicht darauf beschränkt ist, und die schriftlichen Unterlagen sind Eigentum des Lizenzgebers und sind durch die Gesetze der Vereinigten Staaten und anderer Länder und durch internationale Verträge urheberrechtlich geschützt.

### Beschränkungen im Gebrauch und Transfer

2. Sollte diese Softwarelieferung mehrere Medien enthalten (z.B. CD, Karten, Festplatten usw.), dürfen Sie nur die für Ihre Maschine angebrachte Medienart verwenden. Die anderen Medienarten dürfen nicht auf anderen Maschinen verwendet werden oder an Dritte übergeben werden, abgesehen von einem endgültigen Transfer der Software und aller schriftlichen Unterlagen (wie im untenstehenden Paragraphen 4 beschrieben).
3. Sie dürfen nur eine Sicherungskopie der Software herstellen. Unter keinen Umständen dürfen Sie einen Softwaresicherungsschlüssel oder Sicherungsmaßnahmen kopieren oder davon Sicherungskopien herstellen.
4. Sie dürfen das Nutzungsrecht für die Software und die schriftlichen Unterlagen (einschließlich der aktuellen Version und aller vorhergehenden Versionen) an Dritte übertragen, wenn Sie keine Kopie behalten und wenn der Empfänger die Bestimmungen dieses Abkommens in schriftlicher Form akzeptiert. Bei einem solchen Transfer der Lizenz an Dritte erlischt Ihre Lizenz umgehend. Abgesehen von den Bestimmungen dieses Paragraphen sind alle anderen Transfers oder Übertragungen der Nutzungsrechte für diese Software unerlaubt.
5. Sie dürfen die Software nicht benutzen oder eine Nutzung gestatten, wenn eine solche Nutzung der Software irgendwelche Gesetze und Verordnungen der kommunalen oder staatlichen Behörden verletzen würde. Sie verpflichten sich die Software nicht so zu nutzen oder nutzen zu lassen, dass sie damit gegen staatliche, Bundes- oder Lokalgesetze oder Bestimmungen der USA oder gegen ausländische Gesetze oder Bestimmungen, einschliesslich aller Gesetze bezüglich Glücksspiels, Spielens oder geistigen Eigentumsrechts der Software, verstossen.
6. Es ist Ihnen nicht gestattet, die Software abzuändern, zu verändern, zu übersetzen, rückumzuwandeln, zu dekompileieren oder zu zerlegen, oder aus der Software oder eines Teils davon andere Werke abzuleiten. Sie dürfen auch aus der Software, einem Bestandteil der Software oder aus den Datenausgaben der Software keine Hinweise, Bemerkungen, Ratschläge, Wasserzeichen oder andere Markierungen entfernen, verändern, verbergen oder auf andere Art unlesbar machen.
7. Sie akzeptieren, dass die Software und die Urheberschaft, die Systeme, die Ideen, Erfindungen, die Arbeitsweisen, die Dokumentation und alle anderen darin enthaltenen Informationen und alle Versionen, Veränderungen, und Bearbeitungen davon das geistige Eigentum des Lizenzgebers sind, und dass sie durch Straf- und Zivilgesetzgebung und durch die Copyright-, Geschäftsgeheimnis-, Warenzeichen- und die Patentgesetze der Vereinigten Staaten und anderer Länder geschützt sind.

### Beschränkte Garantie

8. Der Lizenzgeber garantiert zu Ihren Gunsten, dass die Software für die angegebene normale Garanzzeit des Lizenzgebers nach Ihrer Annahme der Software in erheblicher Übereinstimmung mit der beiliegenden Dokumentation laufen wird.

### Verpflichtung des Lizenzgebers im Rahmen der Garantie

9. Die ausschließliche Pflicht des Lizenzgebers im Rahmen der vorstehenden Garantie besteht darin, alle geschäftlich vertretbaren Schritte zu unternehmen, um Teile der Software zu berichtigen oder abzuändern, bis sie mit der beiliegenden Dokumentation erheblich übereinstimmen.

Übertragung der Lizenz

10. Der Lizenzgeber gewährt Ihnen eine beschränkte, nicht-ausschliessbare Lizenz zur Vertreibung und/oder Benutzung einer Kopie der Software auf einem einzelnen Merit™ („Gerät“) mit einem einzelnen werksmäßig gestatteten Sicherheitsschlüssel. Der Lizenzgeber behält sich das Recht vor, nach eigenem Ermessen die Software und den Inhalt der Maschine zu verbessern. Sie sind dafür verantwortlich ihren individuellen, vom Lizenzgeber werksmäßig gestatteten Sicherheitsschlüssel, ihr Passwort oder anderweitigen Identifikationsmechanismus instandzuhalten und abzusichern gegen die Nutzung durch eine dritte Partei, und sie akzeptieren die Verantwortung für jegliche Nutzung der besagten Software durch eine dritte Partei mithilfe ihres Identifikationsmechanismus. Obwohl der Lizenzgeber nicht regelmässig Maschinen inspiziert, behält sich der Lizenzgeber das Recht vor, ihre Lizenz umgehend zu kündigen aus Gründen des Missbrauchs oder bei Nichtbefolgung der Bestimmungen in diesem Vertrag. Der Lizenzgeber behält sich ebenfalls das Recht vor, die Software von Zeit zu Zeit nach eigenem Ermessen zu inspizieren oder zu überprüfen. Im Falle, dass der Lizenzgeber Zugang zu dem Gerät wünscht, in dem besagte Software installiert ist, erklären Sie sich bereit, dass sie dem Lizenzgeber, wenn nötig, Erlaubnis und Hilfe beim Zugang zum Gerät verschaffen.

Beschränkungen

11. ABGESEHEN VON DEN BESTIMMUNGEN DES PARAGRAPHEN „BESCHRÄNKTE GARANTIE“ GIBT DER LIZENZGEBER KEINE SONSTIGEN VERSPRECHEN, VERPFLICHTUNGEN ODER GARANTIEEN, OB AUSDRÜCKLICH ODER STILLSCHWEIGEND, FÜR DIE SOFTWARE ODER IHRE BESTANDTEILE ODER FÜR ALLE ANDEREN MATERIALIEN, DIE IHNEN IM RAHMEN DIESES ABKOMMENS ZUR VERFÜGUNG GESTELLT ODER ÜBERLASSEN WERDEN, UND DER LIZENZGEBER LEHNT AUSDRÜCKLICH ALLE ANSPRÜCHE AUF MARKTFÄHIGKEIT UND EIGNUNG DER BESAGTEN MATERIALIEN FÜR DEN GEWÖHNLICHEN GEBRAUCH AB. SOWEIT GESETZESMÄSSIG ZUGELASSEN, SOLLEN DIE HANDELSRECHTLICHE GESETZGEBUNG AUS DEM UNIFORM COMMERCIAL CODE ODER ANDERE GESETZE AUF DIESES ABKOMMEN NICHT ANWENDBAR SEIN.

Haftungsbeschränkung

12. DER LIZENZGEBER HAT KEINERLEI HAFTUNG BEI EINEM ANSPRUCH, EINER FORDERUNG ODER EINER KLAGE, DIE AUF NUTZUNG DER SOFTWARE, DEREN INSTALLIERUNG, DER LEISTUNG DES LIZENZGEBERS ODER DESSEN VERSAGEN IM RAHMEN DIESES ABKOMMENS FÜR JEGLICHE FOLGE-, INDIREKTE, SONDER- ODER NEBENSCHÄDEN BERUHEN, SELBST WENN DER LIZENZGEBER AUF DIE MÖGLICHKEIT EINES SOLCHEN ANSPRUCHES, EINER FORDERUNG ODER EINER KLAGE HINGEWIESEN WURDE. WEITERHIN UND OHNE BESCHRÄNKUNG DES LETZTEN SATZES, DÜRFEN IN ALLEN FÄLLEN DIE IHNEN ZUR VERFÜGUNG STEHENDEN ABHILFEN DIE VON IHNEN FÜR DIE SOFTWARE AN DEN LIZENZGEBER GEZAHLTE SUMME NICHT ÜBERSCHREITEN.
13. DER LIZENZGEBER HAT IN KEINEM FALLE EINE HAFTUNG IHNEN GEGENÜBER FÜR SCHÄDEN, EINSCHLIESSLICH ETWAIGER GEWINNVERLUSTE, NICHT REALISIERTER EINSPARUNGEN ODER ANDERER NEBEN- ODER FOLGESCHÄDEN, DIE AUS IHRER VERWENDUNG, MISSBRAUCH, VERLETZUNG DIESES ABKOMMENS ODER GEBRAUCHSUNFÄHIGKEIT DER SOFTWARE ENTSTEHEN.

Allgemein

14. Die Rechtsgültigkeit und Provisionen dieses Abkommens und der darin enthaltenen Rechte und Pflichten werden durch die Gesetze des Staates von New York bestimmt. Sollten sie diese Vereinbarungen annehmen, dann akzeptieren Sie, dass der ausschliessliche Erfüllungsort und Gerichtsstand bei den Gerichten von New York im Staat New York liegen hinsichtlich aller Streitigkeiten, die diesen Vertrag betreffen, oder die durch Leistung oder Missbrauch der besagten Software entstehen.
15. Merit kann nach eigenem Ermessen dieses Abkommen oder jedes der darin enthaltenen Rechte und Pflichten an Dritte abtreten.
16. Bei Rückfragen über dieses Abkommen oder wenn Sie den Lizenzgeber aus einem anderen Grund kontaktieren wollen, bitte schreiben an: Merit Industries, Inc., 155 Rittenhouse Circle, Bristol, PA 19007, USA.











Please read the enclosed license agreement. Operation of this game constitutes acceptance of the Merit Software License Agreement.

Veillez lire le contrat de licence d'utilisation ci-inclus. Si vous utilisez ce jeu, vous vous engagez à respecter les termes et conditions du contrat de licence d'utilisation du logiciel de Merit.

Bitte beiliegendes Lizenzabkommen durchlesen. Das Merit Software Lizenzabkommen tritt in Kraft, sobald dieses Spiel verwendet wird.