

ATTENTION:

OBSERVE PRECAUTIONS FOR HANDLING ELECTROSTATIC DEVICES

Removal/Installation of Hard Drive - The Vibe and Vibe w/ Coin

NOTE: Do NOT attempt to remove the monitor or motherboard from The Vibe. If these components need to be replaced, contact Merit Customer Service at 1-800-445-9353 or (215) 639-4700 outside the USA and Canada to arrange to have your game sent in for repair.

Hard Drive Removal

1. Turn off and unplug the game.
2. Unlock the lock on the processor cover and loosen the 3 screws on either side of the cover (see Figure 1). Slide the cover away from the connector side of the processor and lift the cover off of the unit.
3. Remove the 3 screws securing the hard drive to the processor (see Figure 2).
4. Disconnect the SA0345-01 I/O and audio harness, then remove the hard drive assembly until you're able to disconnect the hard drive ribbon cable and hard drive power connector. See Figure 2.
5. Remove the 4 screws and shoulder washers fastening the hard drive to the mounting plate.

Hard Drive Installation

1. Fasten the new hard drive to the mounting plate with the 4 screws and shoulder washers.
2. Connect the ribbon cable and power connector to the hard drive, then reconnect the audio harness.
3. Fasten the hard drive to the processor with the 3 screws (see Figure 2).
4. Replace the processor cover and tighten the 3 screws (see Figure 1).
5. Plug in and turn on the game.

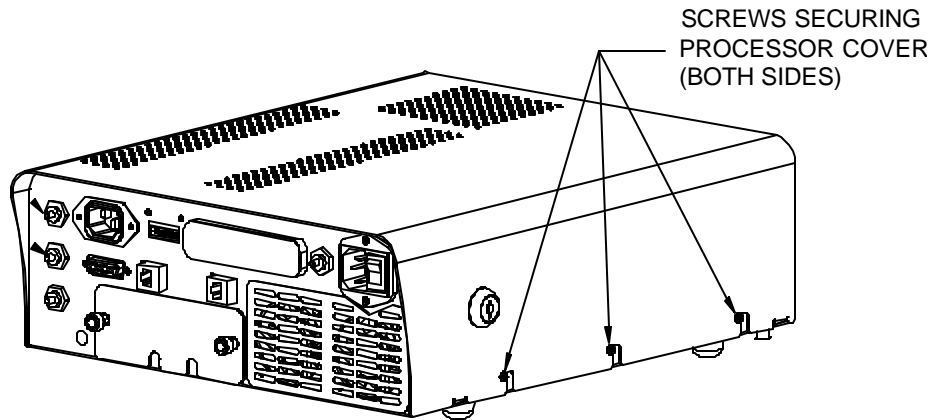

FIGURE 1 - REMOVING PROCESSOR COVER

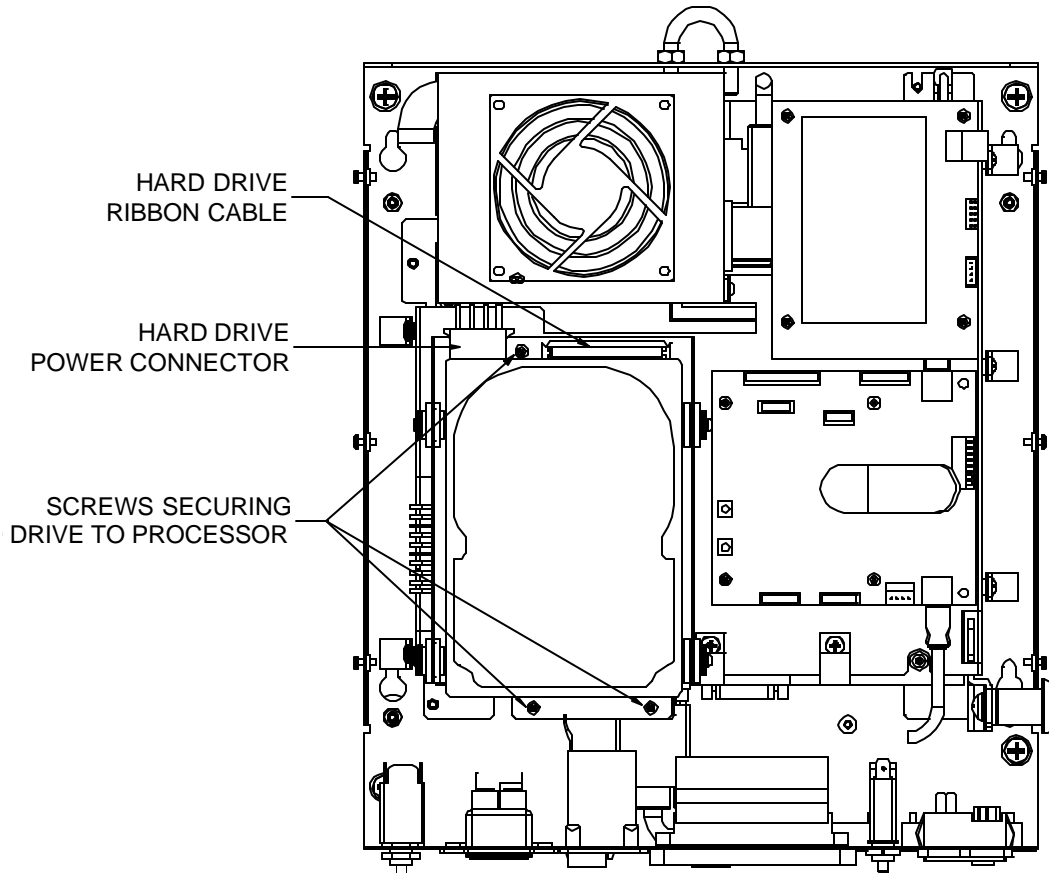

FIGURE 2 - TOP VIEW OF PROCESSOR WITH COVER REMOVED -
REMOVING HARD DRIVE