



MEGATOUCH
E·N·C·O·R·E

Visit the Merit Industries, Inc. Web Site
<http://www.meritind.com>



merit industries, inc.

PM0273-02

Megatouch™ 7 Encore Edition

CONTENTS:

QTY	PART NUMBER	DESCRIPTION
1	SA3012	MEGA 7 U37 (4 MEG)
1	SA3014	MEGA 7 U32 (8 MEG)
1	SA3014	MEGA 7 U38 (8 MEG)
1	SA3045-02	USA, MEGA 7 KEY
1	GL3100-07	ENCORE EDITION DECAL, R, CTOP
1	GL3100-08	ENCORE EDITION DECAL, L, CTOP
1	PM8928-27	ENCORE EDITION SIGN
1	GL2401-12	ENCORE EDITION MARQUEE
2	HW8023-01	13/16" W T-MOULDING

Installing the EPROMS

NOTE: IN ORDER TO INSTALL THIS KIT, YOU MUST BE AT THE SUPER IV LEVEL (PG9255-41) OR HIGHER. IN ORDER TO DETERMINE WHAT LEVEL OF SOFTWARE YOUR GAME IS CURRENTLY RUNNING, LOOK AT THE EPROM AT U38. REFER TO FIGURE 1 FOR LOCATION.

1. Turn off the game and disconnect it from its power source.

NOTE: BEFORE HANDLING THE CRT-260 BOARD OR THE EPROMS, GROUND YOURSELF TO REMOVE ANY STATIC CHARGE THAT MAY BE ON YOUR BODY.

2. Locate and gain access to the CRT-260 PC board (if unsure where to locate your CRT-260 board, see your game manual).
3. Remove the existing program chips from U32, U36, U37 and U38 from the CRT-260 board. Also, remove the security key from U5. (To remove the existing key, you may need to cut away silicone sealant holding the key in place.)
Be extremely careful not to damage the board. See Figure 1 for locations.

4. Install the new EPROMS at U32, U37 and U38 and the new security key at U5.

NOTE: WHEN INSTALLING EPROMS, BE CAREFUL TO OBSERVE THE ORIENTATION OF THE NOTCHES.

AVOID WALKING AROUND WITH THE CHIPS IN YOUR HAND AFTER YOU HAVE REMOVED THEM FROM THE BOX. THIS COULD CAUSE STATIC TO BUILD UP.

5. Put the CRT-260 board back into place and close all doors.
6. Plug the game in and turn on the power.
7. Perform a "2-Button Clear," by turning on the game while simultaneously pressing both the SETUP and CALIBRATE buttons (located behind the cashbox).
8. Confirm that the checksum is as follows:
U32 = C193
U37 = 0E87
U38 = 8B6F
9. If one of the checksum numbers is incorrect, check to make sure that the EPROM is seated properly.

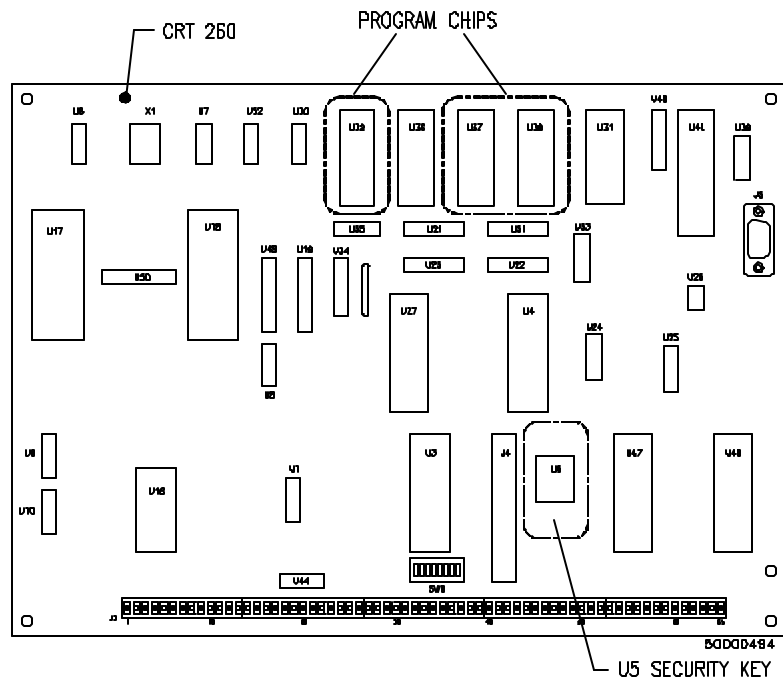

FIGURE 1 - LOCATION OF EPROMS AND SECURITY KEY

Installing the T-Molding and Side Decals

1. Turn off the game and disconnect it from its power source.
2. Unlock and remove the coin mech from the game.
3. Unlock and open the rear door.
4. Disconnect the ground braid and the clear drainage tubing from the hood assembly. See Figure 2.
5. Remove the thumbscrews and washers securing the lid, push the lid forward, and remove it from the game. See Figure 2.
6. Locate the seam on the T-moulding as shown in Figure 2.
7. Using a screwdriver, carefully pry the T-moulding away from the wood side panel working around until entire T-moulding is removed. Repeat the same step for the other side of the game.
8. Install the provided T-moulding. Use a rubber mallet to gently insert the T section of the moulding into the wood side panel. (Make sure that the T-moulding seam is towards the bottom edge of the side panel.) You will need to make relief cuts where the T-moulding bends around the game (see Figure 3). Repeat the same step for the other side of the game.
9. Replace the lid and reconnect the ground strap and clear drainage tubing.
10. Secure the lid to the game using the 2 thumbscrews and washers.
11. Put the coin mech back into the game and lock it.
12. Close and lock the rear door.
13. Once the new T-moulding is in place, remove the existing side decals. (Remove any remaining adhesive residue with an adhesive remover.)
14. When you are finished removing any excess adhesive from the game, wipe the surfaces with alcohol solvent. The surfaces must be clean and free from dirt for the new decals to adhere properly.
15. Partially peel the backing from the top edge of the provided decal. Center the decal on the side of the game and apply the decal. There is a half inch excess around the entire decal to allow for slight error. Cut away the excess decal using the gap between the T-moulding and the wood sides as a guide. Repeat the same step for the other side of the game.
16. Plug in the game and turn on the power.

NOTE: Make sure not to get any adhesive removing solvents or solutions on the touchscreen, as they may damage the touchscreen.

NOTE: BE EXTREMELY CAREFUL WHEN INSTALLING THE T-MOULDING. THE GAME MUST BE TURNED OFF AND THE LID MUST BE REMOVED FROM THE GAME BEFORE USING THE RUBBER Mallet TO INSERT THE T-MOULDING INTO THE SIDE PANEL.

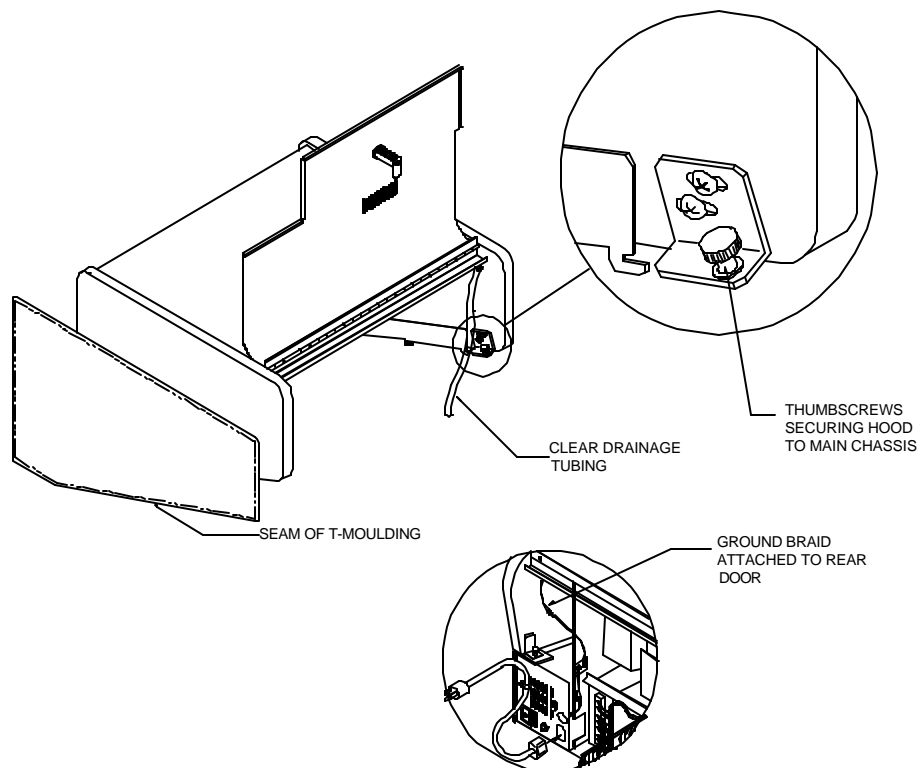

FIGURE 2 - HOOD ASSEMBLY
T-MOULDING PULLED AWAY FROM GAME

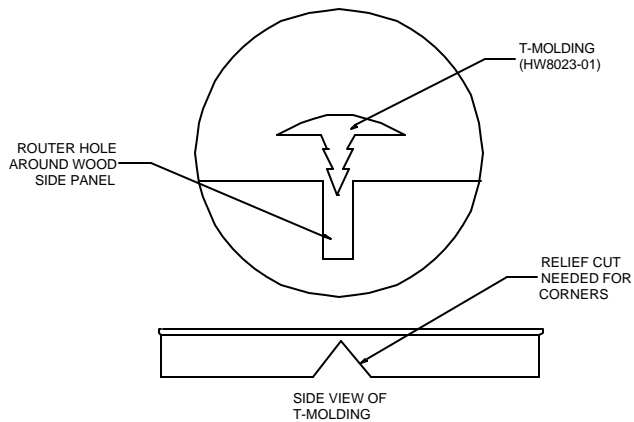

FIGURE 3 - SIDE VIEW OF T-MOULDING IN ROUTER HOLE
T-MOULDING WITH RELIEF CUT

