

TECHNICAL SERVICE BULLETIN

Date: 5/13/96

merit industries, inc.

- Problem:** Monitor displays vertical instability.
- Games affected:** Games manufactured between 8-15-95 and with Type 13, 13" Wells-Gardner monitors.
- Symptoms:** Screen jitters up and down.
- Cause:** Wrong capacitor value for C50.
- Solution:** Reduce feedback by changing the value of the C50 capacitor from 330 μ f to 680 μ f @ 35V (Merit P/N CP2075). *If your game does not exhibit this symptom, the capacitor does not need to be changed.*

13" Countertop

1. Turn off the game and unplug it.
2. Remove the lid assembly. To remove the lid, unscrew the thumbscrews on each side of the chassis, push the lid forward, and pull up. (You may have to disconnect the ground braid that runs from the power entry to the lid.)
3. Disconnect the monitor from its power source. See Figure 1 for location of power wires.
4. Loosen the four (4) nuts (two on each side, at the top) securing the monitor chassis to the main chassis. Slide the monitor chassis out of the grooves holding it to the main chassis.
5. Remove the monitor chassis and lay it on the flat surface on the back of the monitor board.
6. Remove the monitor controls from the cabinet so that the monitor chassis can be removed.
7. Using a nut driver or pliers, unscrew the two (2) screws on the edge of the board (one in each corner). See Figure 1.
8. Remove the two (2) nuts holding the bracket attached to the transformer heatsink. See Figure 1.
9. Gently move the monitor board out from the monitor chassis. Rest the monitor in a semi-vertical position, with the back edge of the board resting between the two studs and the edge of the chassis, and the solder side facing out.
10. Locate the capacitor at C50. Heat the solder from the solder-side of the board and remove the existing capacitor. See Figure 1 for location.
11. Install the new capacitor and solder it in place.
12. Replace the monitor board in the monitor chassis.
13. Put the monitor chassis back inside the cabinet and secure it in place.

14. Replace the lid and close the rear door.
15. Plug in the game and power up.

13" Cabaret

1. Turn off the game and unplug it.
2. Open the rear door to access the monitor section.
3. Disconnect the monitor from its power source. See Figure 1 for location of power wires.
4. Using a nut driver or a pliers, unscrew the two (2) screws on the edge of the board (one in each corner). See Figure 1.
5. Remove the two (2) nuts holding the bracket attached to the transformer heatsink. See Figure 1.
6. Gently move the monitor board out

the back edge of the board resting between the two studs and the edge of the chassis, and the solder side facing out. See Figure 1.

7. Locate the capacitor at C50. Heat the solder from the solder-side of the board and remove the existing capacitor. See Figure 1 for location.
8. Install the new capacitor and solder it in place.
9. Replace the monitor board in the monitor chassis and reattach the monitor power.
10. Close the rear door, plug in the game and power up.

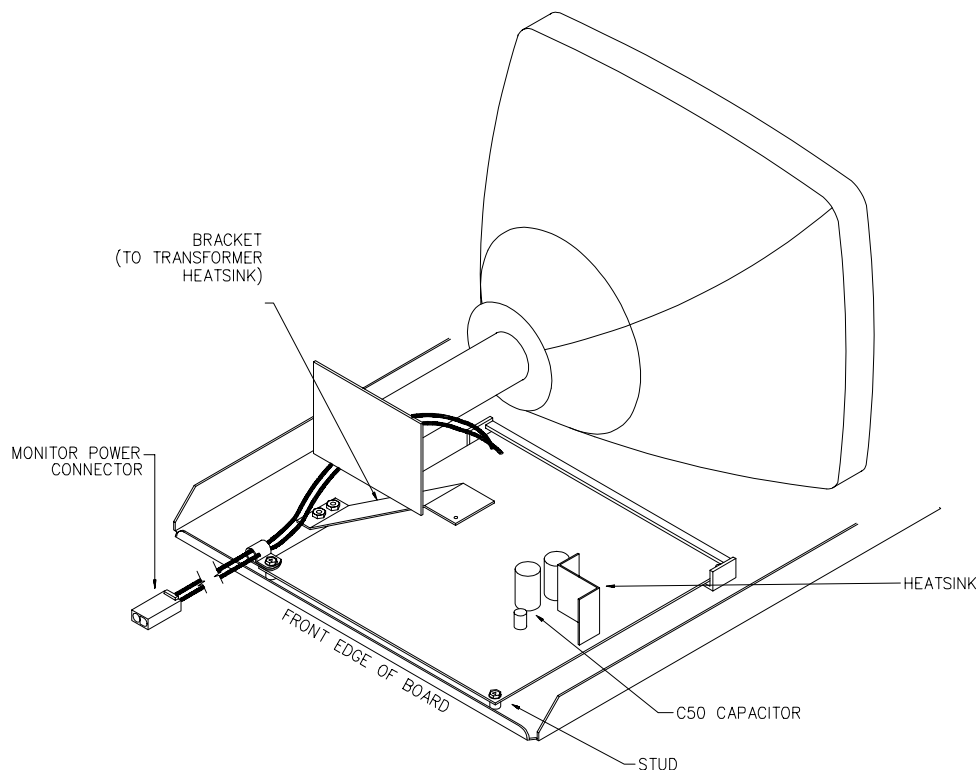

from the monitor chassis. Rest the monitor in a sFigure 1 - Type 13 Wells-Gardner Monitor Board Diagram