

# TECHNICAL SERVICE BULLETIN

Date: 7/17/95

merit industries, inc.

- Problem:** Poor touchscreen performance.
- Games affected:** 19" upright touchscreens.
- Symptoms:** Calibration "drifts" when simultaneously touching the screen and the bezel or touchscreen just not working properly.
- Cause:** Ineffective grounding of the monitor bezel door or the monitor is not oriented properly in relation to the bezel door.
- Solution:** Provide a better ground connection by removing the paint from under the ground strap screw on the bezel door hinge. Re-orient the monitor in relation to the bezel door.

*BEFORE PROCEEDING WITH THE FOLLOWING STEPS, POWER DOWN THE GAME.*

## **Grounding the monitor door: Refer to Figure 1.**

1. Open the monitor bezel door by unhooking the latches inside the coin mech section, above the mech, to the left and right.
2. Locate the ground strap screw attached to the door hinge on the top of the machine.
3. Remove the screw, lock washer and ground strap and scrape away the paint underneath the screw head, using sandpaper, a file or a small grinder.
4. Reattach the screw, lock washer and ground strap and close the bezel door.
5. Power up the game and recalibrate the touchscreen. **YOU MUST RECALIBRATE THE TOUCHSCREEN AFTER OPENING THE MONITOR DOOR.**

**Repositioning the monitor to provide the proper alignment with the bezel: Refer to Figure 2.**

The bezel door should rest firmly against the neoprene tape around the monitor, WITHOUT CRUSHING THE TAPE. THE METAL DOOR CANNOT TOUCH THE MONITOR SCREEN OR THE TOUCHSCREEN WILL NOT CALIBRATE.

1. Open the rear door to access the monitor/CPU section and the monitor bezel door..
2. Loosen the four bolts (two in the front, two in the rear) securing the monitor shelf to the cabinet. The bolts holding the front of the shekf can be accessed from beneath the shelf after opening the monitor door. See Figures 1 and 2 for screw and bolt locations.
3. Adjust the two screws at the back of the shelf to move the monitor assembly closer to, or farther from, the bezel door.
4. Once the shelf is in the desired position, resecure the four mounting bolts.
5. Close the rear door and power up the game.
6. Recalibrate the touchscreen.

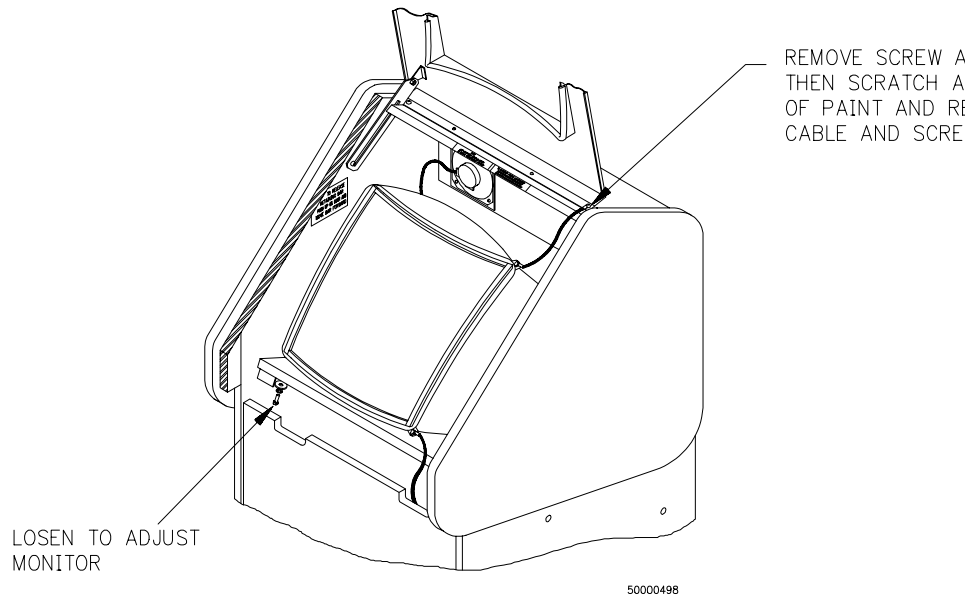

**Figure 1 - Location of Ground Strap and Bezel Door Hinge and Front Monitor Bolts**

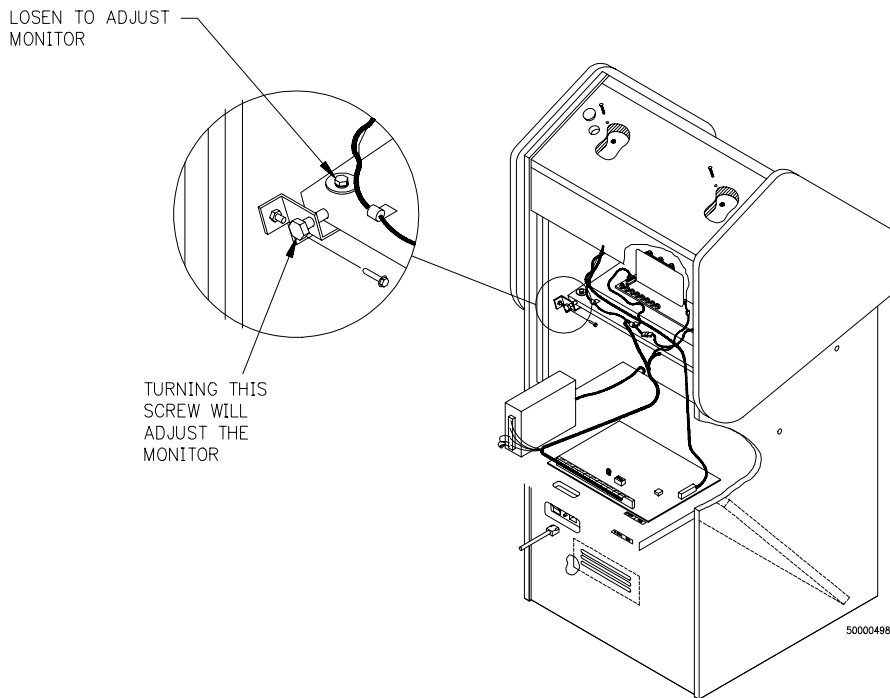

**Figure 2 - Location of Monitor Adjustment Screws**