



# TECH NOTES

Date: 8-30-96

merit industries, inc.

Re: Merit will be implementing several enhancements to the Scorpion™ 9000 dart game, beginning with serial number 392000 (for upright models) and serial number 460931 (for wall mount models). *No field upgrades are necessary.* This note is to inform you of the changes made to the product and inform you of the new numbers of the affected replacement parts. These changes include:

Program update - new handicapping features and NDA stats  
New Spider and Segment materials - more durable materials  
New Target Rubber - long-life compound

## Program Changes

(Modifications to programs numbered 4978-XX R3)

1. The Scorpion™ 9000 dart program now supports the new National Dart Association (NDA) feats used to determine player rankings. For '01 games, the new NDA feats are points remaining and total darts thrown; for cricket games, the new NDA feats are total marks and total darts thrown. The order in which '01 feats are displayed has been changed so Total Darts Thrown (TDT) is displayed second and the two new Cricket feats are displayed after the final score display.

To accommodate split stats and handicapped games, a new feat was created: Total Points Scored. This feat divided by the Total Darts Thrown allows for the calculation of correct PPDs for the NDA.

2. A new sub-test has been added to Operator Test 0. The new sub-test allows the operator to toggle the TPS display on or off, as well as select whether to display only the new NDA feats or the NDA feats along with the standard list of feats. The Double In button is used to toggle the TPS display and the Team button is used to select the feats list.
3. The '01 points-per-dart (PPD) handicapping range has been extended from a range of 10 to 35 points-per-dart to 10 to 40 points-per-dart. The greater range allows for more accurate handicapping for league play.
4. The Cricket hits-per-round (HPR) handicapping system no longer uses the Spot Cricket table to determine the number of spots given for handicapping (*although Spot Cricket has not been changed*).

Players with HPR averages of 0.0 to 2.9 receive one (1) mark for each .15 difference in HPR average; players with HPR averages of 3.0 or more receive one (1) mark for each .20 difference in HPR average. Use the left column of the chart to determine the number of marks for players with HPR averages of 0.0-2.9; use the right column to determine the number of marks for players with HPR averages of 3.0 or more. (Example: Player 1 has an

HPR average of 2.0 and Player 2 has an HPR average of 3.2 and Player 3 has an HPR average of 3.7, for differences of 1.2 and .5, respectively. Player 1 (using the scale in the left column) receives 11 marks and Player 2 (using the scale in the right column) receives 2 marks).

(HPR AVG.0-2.9) HPR Difference	(HPR AVG.3.0+) HPR Difference	20	19	18	17	16	15	◎
0.0	0.0 - 0.1	○○○	○○○	○○○	○○○	○○○	○○○	○○○
0.1 - 0.2	0.2 - 0.3	●○○	○○○	○○○	○○○	○○○	○○○	○○○
0.3	0.4 - 0.5	●○○	○○○	○○○	○○○	○○○	○○○	●○○
0.4 - 0.5	0.6 - 0.7	●○○	●○○	○○○	○○○	○○○	○○○	●○○
0.6	0.8 - 0.9	●○○	●○○	●○○	○○○	○○○	○○○	●○○
0.7 - 0.8	1.0 - 1.1	●○○	●○○	●○○	●○○	○○○	○○○	●○○
0.9	1.2 - 1.3	●○○	●○○	●○○	●○○	●○○	○○○	●○○
1.0 - 1.1	1.4 - 1.5	●○○	●○○	●○○	●○○	●○○	●○○	●○○
1.2	1.6 - 1.7	●●○	●○○	●○○	●○○	●○○	●○○	●○○
1.3 - 1.4	1.8 - 1.9	●●○	●●○	●○○	●○○	●○○	●○○	●○○
1.5	2.0 - 2.1	●●○	●●○	●●○	●○○	●○○	●○○	●○○
1.6 - 1.7	2.2 - 2.3	●●○	●●○	●●○	●●○	●○○	●○○	●○○
1.8	2.4 - 2.5	●●○	●●○	●●○	●●○	●●○	●○○	●○○
1.9 - 2.0	2.6 - 2.7	●●○	●●○	●●○	●●○	●●○	●●○	●○○
2.1	2.8 - 2.9	●●○	●●○	●●○	●●○	●●○	●●○	●●○

- 321 ZAP target display will now show a BACK-ZAP value if a player is within range for a BACK-ZAP. A BACK-ZAP is when a player ties the opponent's score by exceeding 321 and coming *back* to the opponent's score for the ZAP. A BACK-ZAP target is indicated by the three (3) cricket LEDs lit below the target display. In the example shown below, Player 1 has 310 points and Player 2 has 300 points. To BACK-ZAP Player 2, Player 1 must score 32 points (the number of points Player 1 is shy of 321 + the number of points Player 2 is shy of 321).

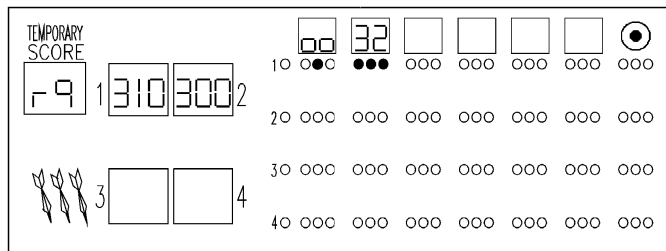

- the Double In option is chosen in 321 ZAP, a player must double-in again after being ZAPPED back to zero.

## Target Changes

(Modifications to the target spider, segments and rubber)

- The .093" thick sheet of black neoprene that we currently use behind our dart target is being replaced by a two-layer "sandwich" of .062" black neoprene and .031" brown urethane. This new combination of materials will be more durable and provide longer life for the rubber and the matrix switch. (The new urethane sheet cannot be added over the current neoprene as

the combination would be too thick, however the new rubber combination can be used with existing target assemblies).

2. New material is being used to fabricate the spider and target segments, making them more resistant to any cracking or chipping. If replacement parts are needed, Merit suggests replacing the entire spider/target segments assembly as the new parts will not fit properly with the older parts. To differentiate between spiders, compare them: the new spiders are shinier than those used previously. See the chart below for the replacement part numbers.

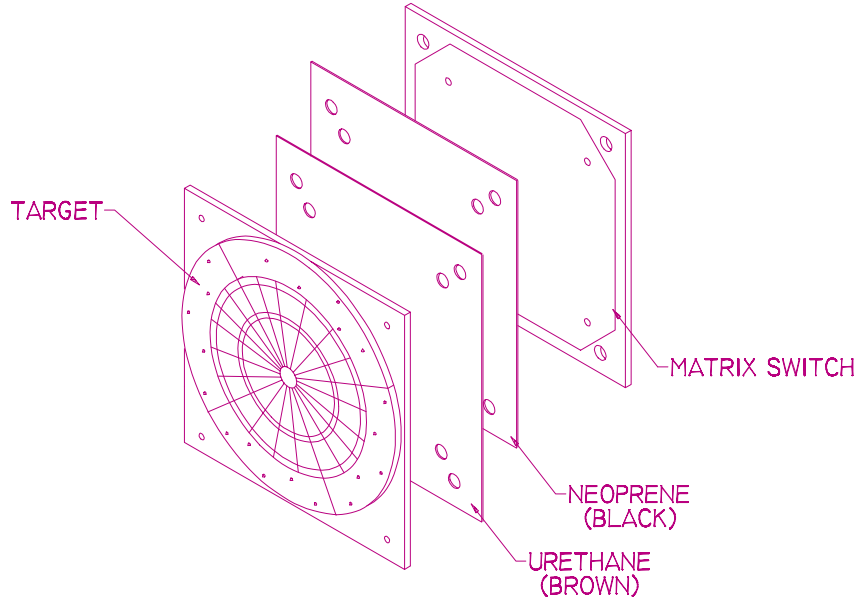

SPIDER/TARGET SEGMENT ASSEMBLIES		
New part #	Description	Obsolete part #
SB1506-02	SPIDER WITH SEGMENTS, SMTGT-S, BLACK-4COLOR	SB1506
SB1506-03	SPIDER WITH SEGMENTS, SMTGT-S, WHITE-RED/BLUE	SB1502-0B
SB1484-02	SPIDER WITH SEGMENTS, LGTGT-S, BLACK-4COLOR	SB1484
SB1484-03	SPIDER WITH SEGMENTS, LGTGT-S, WHITE-RED/BLUE	SB1495

TARGET RUBBER		
New part #	Description	Obsolete part #
HW8012-02-0A*	TARGET SHEET, .NEOPRENE, .062	HW8012-0A
HW8012-03-0A*	TARGET SHEET, .URETHANE, .031	

\*The two (2) new target rubber parts must be used as a set to replace the single sheet used previously.

For more information, contact Merit Customer Service at 1-800-445-9353.