



merit industries, inc.

FIELD BULLETIN

Date: 3-19-97

- Issue:** Ultrasonic sensor not working properly.
- Games affected:** Scorpion™ dart games with serial numbers 392740 to 393051 and Merkur dart games with serial numbers 450182 to 450611 that are exhibiting problems with the ultrasonic sensor.
- Symptoms:** Automatic player change not working.
- Cause:** The exposed end of the unused black wire, concealed in the orange, ultrasonic cable, is touching the neighboring, uninsulated drain wire (the drain wire does have a piece of black insulation covering the section outside of the orange covering, but it is not insulated inside the orange covering).
- Solution:** Put a piece of electrical tape around both exposed ends of the black wire (the orange wire runs from inside the ultrasonic sensor assembly to a 6-pin connector at the CPU board).

Insulating the Exposed Wire

1. Turn off the game.
2. Access the back of the ultrasonic sensor, by removing the assembly from the target section. The ultrasonic assembly is removed by loosening the wingnuts securing it to the top of the target section. See Figure 1 for the location of the ultrasonic sensor assembly. NOTE: THE WIRES SHOULD NOT TOUCH THE ULTRASONIC SENSOR DIAPHRAGM.
3. Using Figure 2, locate the unused, black wire and place a piece of electrical tape around the exposed end.
4. Follow the orange cable to its connector on the CPU board. Disconnect the cable and peel back the shrink wrap around the end of the orange cable to locate the unused, black wire.
5. Repeat Step 3, above and re-secure the shrink wrap, around the end of the orange cable, with a piece of electrical tape.
6. Reconnect the ultrasonic cable to the CPU board and reinstall the ultrasonic assembly
7. Turn on the game.

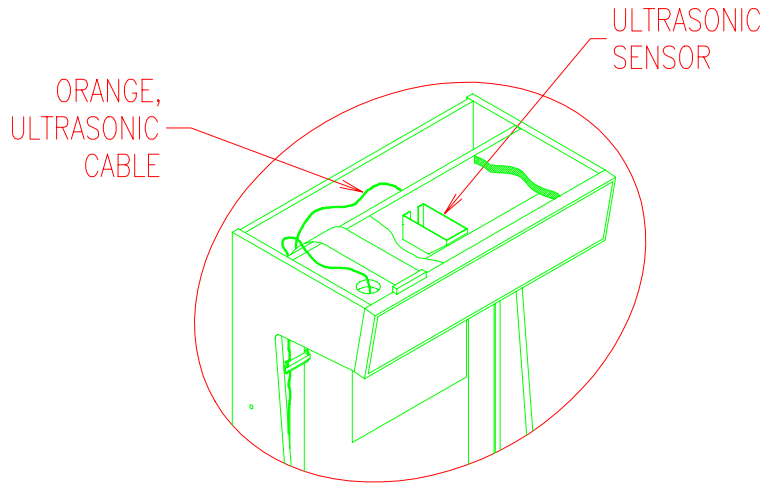

FIGURE 1 - LOCATION OF ULTRASONIC SENSOR

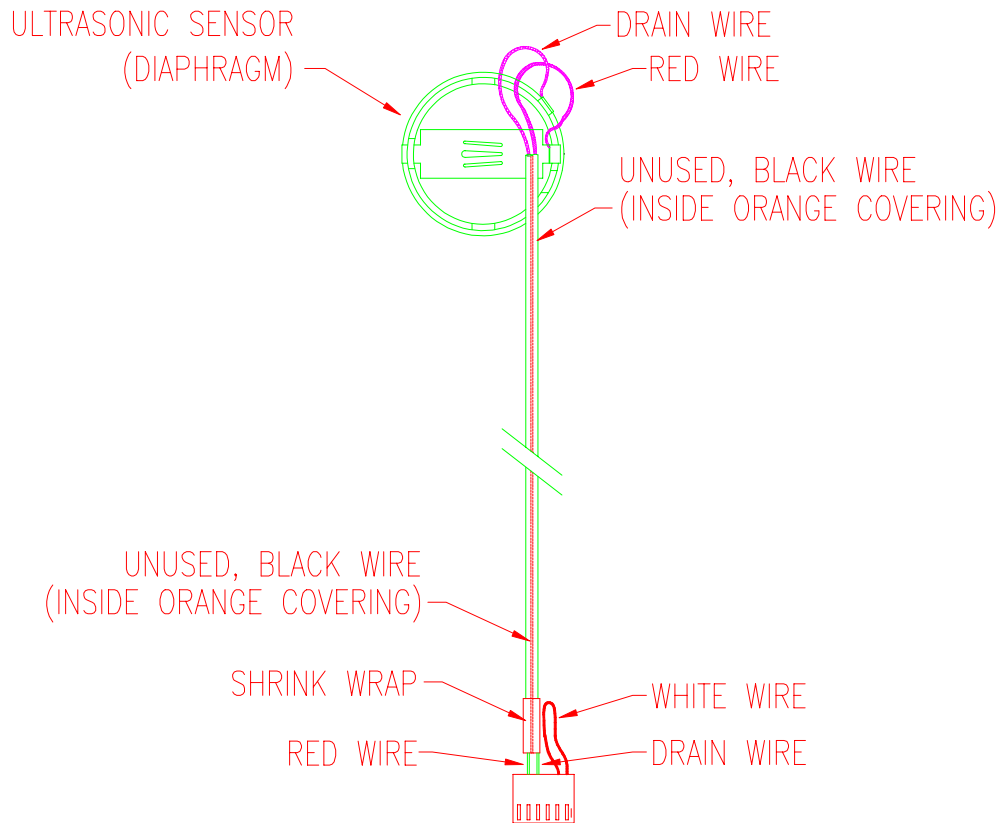

FIGURE 2 - LOCATION OF UNUSED ULTRASONIC WIRE